

# Style SA-7

Y-Strainer

Carbon Steel (ASTM A 216, Grade WCB)

150 lb. & 300 lb. Butt Weld

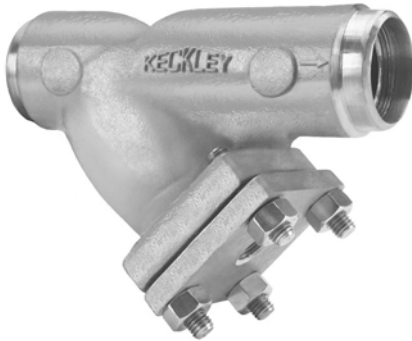

## Cast Carbon Steel Y-Strainer

### APPLICATIONS

Steam, water, oil or gas where protection from foreign matter in a pipeline is required.

### CONSTRUCTION

The Keckley Style SA-7 strainers are constructed from rugged carbon steel castings and are machined to exacting specifications.

Style SA-7 butt weld connections will be machined to match schedule 40 pipe.

### FEATURES

The Keckley Style SA-7 strainer features a machined groove in both the body and cover for proper screen alignment and to ensure accurate reseating when servicing is required. The gasket is 304 stainless steel spiral wound and is compressed between the body and cover (for maximum strength and durability) and designed for high pressure and high temperature service. All Keckley Style SA-7 strainers have stainless steel studs and nuts and can be furnished with a steel blow-off plug upon request.

Blind covers are available upon request.

### SCREENS

Standard perforated 304 stainless steel screens are spot welded along the seam for maximum strength. Different size perforations in stainless steel, monel, brass, or wire mesh are available to meet specific media requirements. If the media is not indicated, screens for *steam* will be supplied.

### SELF CLEANING

Self cleaning is accomplished by opening the valve or drain plug connected to the blow-off port. **Warning:** See Maintenance Instructions on page S6 of the Strainer Information Section for additional precautions and detailed information on servicing the strainer.

### WORKING PRESSURES – NON SHOCK

NOM. RATING	MEDIA	1/2" to 12"	15 mm to 300 mm
150# (BUTT WELD)	STEAM	150 PSI @ 565°F	1035 KPa @ 296°C
	W.O.G.	285 PSI @ 100°F	1966 KPa @ 38°C
NOM. RATING	MEDIA	1/2" to 12"	15 mm to 300 mm
300# (BUTT WELD)	STEAM	300 PSI @ 838°F	2069 KPa @ 448°C
	W.O.G.	740 PSI @ 100°F	5104 KPa @ 38°C

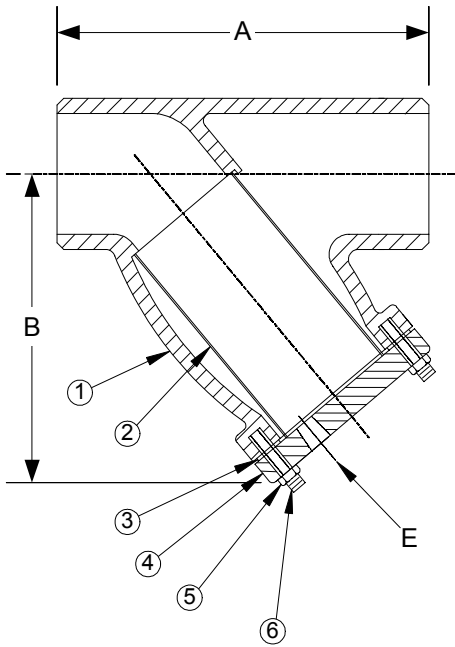

# Style SA-7

**Y-Strainer, 150 lb. & 300 lb. Butt Weld**  
**Cast Carbon Steel (ASTM A 216, Grade WCB)**

PARTS LIST		
ITEM	DESCRIPTION	MATERIAL
1	BODY	CAST CARBON STEEL (ASTM A 216, GRADE WCB)
2	SCREEN	STAINLESS STEEL (304)
3	GASKET	SPIRAL WOUND STAINLESS STEEL (304)
4	COVER	CAST CARBON STEEL (ASTM A 216, GRADE WCB)
5	NUTS	ASTM A 194, GRADE 2H
6	STUDS	ASTM A 193, GRADE B7

Optional: Blow-off Plug, Carbon Steel (ASTM A 105)

### STANDARD SCREENS SUPPLIED

SIZE		SCREEN GAGE	SCREEN PERFORATION					
in	mm		FOR STEAM		FOR LIQUID		OPEN AREA	
			in	mm	AREA	in	mm	AREA
1/2 to 4	15 to 100	28	3/64	1.2	33%	1/16	1.6	30%
5 to 10	50 to 250	22	3/64	1.2	33%	1/8	3.2	43%
12	300	22	1/16	1.6	30%	1/8	3.2	43%

Standard screens supplied are for **steam service**, unless otherwise specified.  
Options: Other perforations, meshes, and screen materials are available.

SIZE		DIMENSIONS										WEIGHTS			
		A				B				E		150#		300#	
		150#	300#	150#	300#	150#	300#	150# & 300#	150#	300#					
in	mm	in	mm	in	mm	in	mm	in	mm	in	mm	lbs	kgs	lbs	kgs
1/2	15	6-1/2	165	6-1/8	156	3-3/4	95	3-3/4	95	3/8	10	7	3	6	3
3/4	20	7-3/8	187	7-3/4	197	4-1/4	108	4-1/4	108	1/2	15	11	5	13	6
1	25	7-3/8	187	7-7/8	200	4-1/4	108	4-1/4	108	1/2	15	11	5	13	6
1-1/4	32	7	178	8-1/8	206	5-1/8	130	5-1/8	130	1/2	15	12	5	19	9
1-1/2	40	7-1/8	181	8-1/4	210	5-1/8	130	5-1/8	130	1/2	15	14	6	19	9
2	50	7-7/8	200	9-1/2	241	6-1/16	154	6-1/16	154	1/2	15	22	10	33	15
2-1/2	65	9-3/4	248	10-3/8	264	6-1/2	165	6-1/2	165	1	25	32	15	44	20
3	80	10-1/16	256	12	305	7-7/16	189	7-5/16	186	1	25	41	19	58	26
4	100	12-1/8	308	14-1/2	368	8-15/16	227	8-15/16	227	1-1/2	40	63	29	90	41
5	125	15-1/2	394	19-5/16	491	13-3/8	340	13-3/8	340	2	50	111	50	180	82
6	150	18-1/2	470	19-5/16	491	13-1/8	333	13-1/8	333	2	50	136	62	180	82
8	200	21-3/8	543	23-3/8	594	15-11/16	398	15-7/8	403	2	50	212	96	304	138
10	250	26	660	27-3/8	695	18-7/16	468	18-7/16	468	2	50	280	127	470	213
12	300	29-7/8	759	32	813	21-3/16	538	23-1/16	586	2	50	460	209	709	322

Larger sizes available upon request.  
Certified dimensional drawings are available upon request.  
†This table reflects only the nearest metric equivalents.

### TOTAL SCREEN AREA

Size	(in <sup>2</sup> )	Size	(in <sup>2</sup> )	Size	(in <sup>2</sup> )
2"	30.28	4"	91.89	8"	342.86
2-1/2"	46.91	5"	209.41	10"	532.80
3"	57.62	6"	241.18	12"	600.71

\*See DETERMINING RATIOS on page S5 of the Strainer Information Section for calculating NET FREE AREA of the screen to inside pipe area.

### PRESSURE vs. TEMPERATURE CHART

150# & 300# Butt Weld Cast Carbon Steel (ASTM A 216, Grade WCB)

