

Style SB-7

Y-Strainer

Carbon Steel (ASTM A 216, Grade WCB)

600 lb. Threaded

600 lb. Socket Weld



Cast Carbon Steel Y-Strainer

APPLICATIONS

Steam, water, oil or gas where protection from foreign matter in a pipeline is required.

CONSTRUCTION

The Keckley Style SB-7 strainers are constructed from rugged carbon steel castings and are machined to exacting specifications.

Socket Weld bore is in compliance with ASME B16.11 unless otherwise specified.

FEATURES

The Keckley Style SB-7 strainer features a machined groove in the body and cap for proper alignment and to ensure accurate reseating when servicing is required. This strainer has a straight threaded cap and is furnished standard with a NPT blow-off connection. The gasket is 304 stainless steel spiral wound and is compressed between the body and cap (for maximum strength and durability) and designed for both high pressure and high temperature service. Keckley Style SB-7 strainers can be furnished with a carbon steel blow-off plug upon request.

SCREENS

Standard perforated 304 stainless steel screens are spot welded along the seam for maximum strength. Different size perforations and meshes are available in stainless steel, monel, and brass to meet specific media requirements. If media is not indicated, screens for *steam* will be supplied.

SELF CLEANING

Self cleaning is accomplished by opening the valve or drain plug connected to the blow-off port. **Warning:** See Maintenance Instructions on page S6 of the Strainer Information Section for additional precautions and detailed information on servicing the strainer.

WORKING PRESSURES – NON SHOCK

NOM. RATING	MEDIA	1/4" to 3"	8 mm to 80 mm
600# (THREADED & SOCKET WELD)	STEAM	600 PSI @ 838°F	4138 KPa @ 448°C
	W.O.G.	1480 PSI @ 100°F	10208 KPa @ 38°C

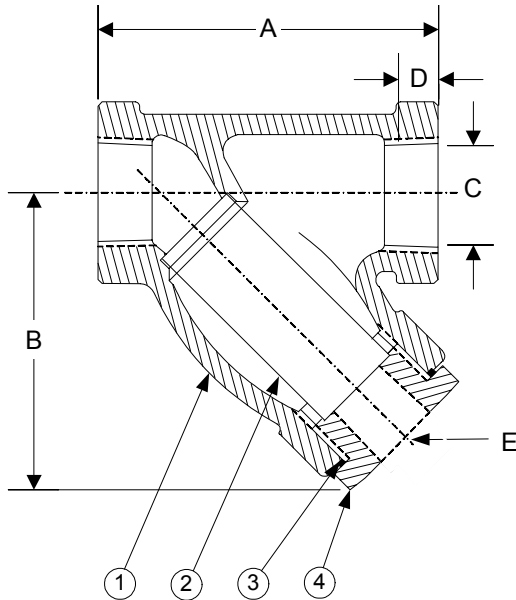

Style SB-7

Y-Strainer, 600 lb. Threaded & Socket Weld
 Cast Carbon Steel (ASTM A 216, Grade WCB)

PARTS LIST

ITEM	DESCRIPTION	MATERIAL
1	BODY	CAST CARBON STEEL (ASTM A 216, GRADE WCB)
2	SCREEN	STAINLESS STEEL (304)
3	GASKET	SPIRAL WOUND STAINLESS STEEL (304)
4	CAP	CAST CARBON STEEL (ASTM A 216, GRADE WCB)

Optional: Blow-off Plug, Carbon Steel (ASTM A 105)

STANDARD SCREENS SUPPLIED

SIZE		SCREEN GAGE	SCREEN PERFORATION					
in	mm		FOR STEAM		OPEN AREA	FOR LIQUID		OPEN AREA
			in	mm		in	mm	
1/4 to 3	8 to 80	21	3/64	1.2	33%	1/16	1.6	30%

Standard screens supplied are for **steam service**, unless otherwise specified.

Options: Other perforations, meshes, and screen materials are available.

SIZE		DIMENSIONS										WEIGHTS	
		A		B		C		D		E			
in	mm	in	mm	in	mm	in	mm	in	mm	in	mm	lbs	kgs
1/4	8	2-15/16	75	2-7/16	62	.555	14	3/8	10	1/4	8	3	1
3/8	10	2-15/16	75	2-7/16	62	.690	18	3/8	10	1/4	8	3	1
1/2	15	2-15/16	75	2-7/16	62	.855	22	3/8	10	1/4	8	3	1
3/4	20	3-11/16	94	3	76	1.065	27	1/2	13	3/8	10	5	2
1	25	4-9/16	116	4-5/16	110	1.330	34	1/2	13	3/8	10	6	3
1-1/4	32	4-15/16	125	4-3/16	106	1.675	43	1/2	13	3/4	20	8	4
1-1/2	40	5-9/16	141	4-11/16	119	1.915	49	1/2	13	3/4	20	10	5
2	50	6-15/16	176	6-1/4	159	2.406	61	5/8	16	1	25	16	7
2-1/2	65	12	305	9-3/8	238	2.906	74	5/8	16	1-1/4	32	43	20
3	80	12	305	9-3/8	238	3.535	90	5/8	16	1-1/4	32	43	20

Certified dimensional drawings are available upon request.

†This table reflects only the nearest metric equivalents.

FLOW COEFFICIENTS

Size	C _v	Size	C _v	Size	C _v
1/2"	9.5	1-1/4"	44.9	2-1/2"	129.7
3/4"	18.7	1-1/2"	61	3"	161.3
1"	30	2"	98		

TOTAL SCREEN AREA

Size	(in ²)	Size	(in ²)	Size	(in ²)
1/2"	2.75	1-1/4"	12.79	2-1/2"	78.14
3/4"	4.71	1-1/2"	16.33	3"	78.14
1"	10.08	2"	27.04		

*See DETERMINING RATIOS on page S5 of the Strainer Information Section for calculating NET FREE AREA of the screen to inside pipe area.

PRESSURE vs. TEMPERATURE CHART

600# Threaded & Socket Weld Cast Carbon Steel (ASTM A 216, Grade WCB)

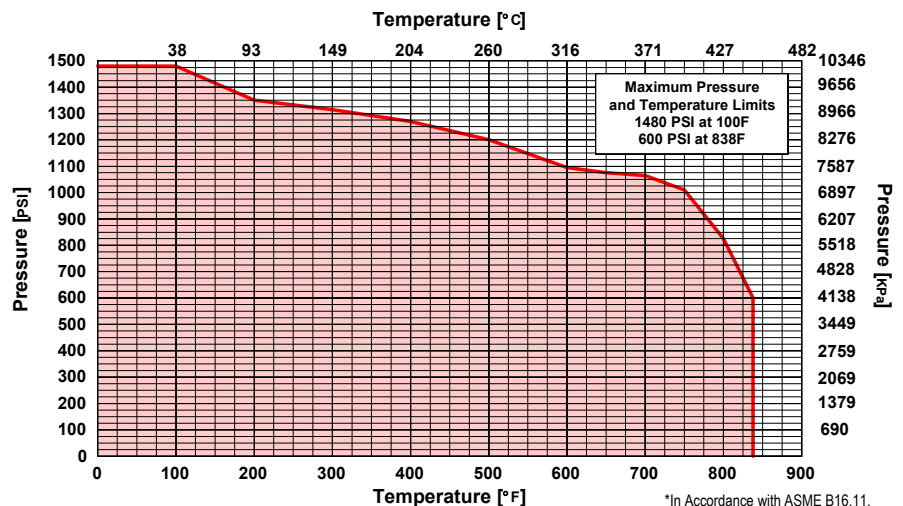

*In Accordance with ASME B16.11.