

DRAWING NO.
AL 105850

PARTS LIST		
ITEM	DESCRIPTION	MATERIAL
1	Body	Stainless Steel (ASTM A 351, CF8M)
2	Tailpiece	Stainless Steel (ASTM A 351, CF8M)
3	Ball	Stainless Steel (ASTM A 351, CF8M) or 316SS
4	Stem	Stainless Steel (ASTM A 276, 316)
5	Seat (2)	R-PTFE
6	Thrust Washer	PTFE
7	Stem Packing	Graphite
8	Packing Gland	Stainless Steel (ASTM A 351, CF8M)
9	Retaining Ring	Stainless Steel (300 Series SS)
10	Lock Plate	Stainless Steel (304SS)
11	Body Gasket	Graphite
12	Handle	Stainless Steel (300 Series SS)
13	Handle Extension*	Carbon Steel
14	Grounding Ball (2)	Stainless Steel (316SS)
15	Grounding Spring (2)	Stainless Steel (304SS)
16	Handle Bolt	Stainless Steel (304SS)
17	Stop Bolt	Stainless Steel (304SS)
18	Packing Bolt (2)	Alloy Steel (ASTM A 193, B8)
19	Belleville Washers	Stainless Steel (300 Series SS)
20	Packing Nut (2)	Alloy Steel (ASTM A 194, 8)
21	Body Stud Bolts	Alloy Steel (ASTM A 193, B8)
22	Body Nuts	Alloy Steel (ASTM A 194, 8)
23	Handle Ext. Bolt*	Stainless Steel (304SS)

*Note: Size 2-1/2" to 6" only.

BODY PRESSURE & TEMPERATURE RATINGS - NON SHOCK	
MEDIA	1½" to 8"
W.O.G.	275 PSI @ 100°F
Saturated Steam (WSP)	195 PSI @ 386°F

Size	ISO Pattern	WEIGHT (lbs)
1-1/2	F07	15.4
2	F07	21.8
2-1/2	F07	37.0
3	F07	47.1
4	F10	83.6
6	F10 & F12	178.9
8	F14	322.6

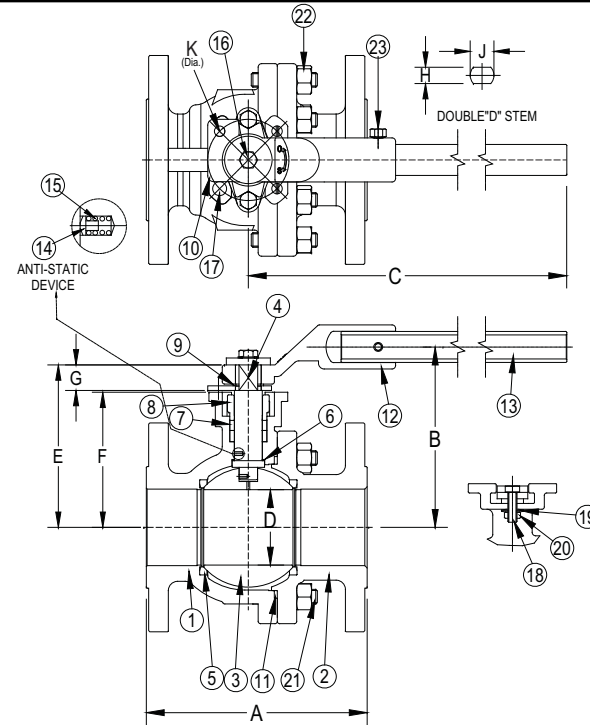
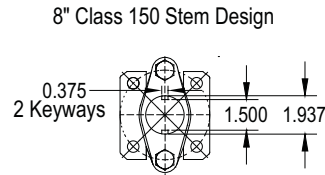

SIZE	DIMENSIONS (in)										
	in	A	B	C	D	E	F	G	H	J	K
1-1/2	1-1/2	6.5	4.88	10.02	1.50	4.13	3.35	0.77	0.55	0.71	2.76
2	2	7.0	5.20	10.02	2.00	4.45	3.64	0.77	0.55	0.71	2.76
2-1/2	2-1/2	7.5	6.12	15.94	2.50	5.51	4.59	0.87	0.67	0.87	2.76
3	3	8.0	6.81	15.94	3.00	6.20	5.28	0.87	0.67	0.87	2.76
4	4	9.0	7.72	18.11	4.00	7.16	6.18	0.91	0.67	1.03	4.02
6	6	15.5	9.88	24.02	6.00	9.35	7.80	1.50	0.91	1.37	4.02 & 4.92
8	8	18.0	N/A	N/A	8.00	13.33	10.45	2.87	N/A	N/A	5.51

Product Numbers†

BVF2RF2FSSRGSL-150
BVF2RF2FSSRGSL-200
BVF2RF2FSSRGSL-250
BVF2RF2FSSRGSL-300
BVF2RF2FSSRGSL-400
BVF2RF2FSSRGSL-600
BVF2RF2FSSRGSL-800

 3400 CLEVELAND SKOKIE ILLINOIS	DRAWING NO. AL 105850
	PART NO.
DIMENSIONAL ASSEMBLY	SCALE: NTS
Style BVF2 150lb. Split-body	DATE: 03/19/2015
Ball Valves	DR. BY DSF
MAT'L: (As Noted Above)	REQ. ---