

Style BDI

Y-Strainer

Ductile Iron (ASTM A 536, Grade 65-45-12)

Class 300 NPT



Ductile Iron Y-Strainer

APPLICATIONS

Steam, water, oil or gas where protection from foreign matter in a pipeline is required.

CONSTRUCTION

The Keckley Style BDI strainers are constructed from rugged ductile iron castings that are machined to exacting specifications.

FEATURES

The Keckley Style BDI features a tapered bushing and is furnished standard with a NPT blow-off connection and can be supplied with an iron blow-off plug upon request.

SCREENS

Standard screens are 20 mesh 304 stainless steel and are spot welded for maximum strength. Different size perforations and meshes are available in stainless steel, monel, and brass to meet specific media requirements. If media is not indicated, screens for *water* will be supplied.

SELF CLEANING

Self cleaning is accomplished by opening the valve or drain plug connected to the blow-off port. **Warning:** See Maintenance Instructions on page **S6** of the Strainer Information Section for additional precautions and detailed information on servicing the strainer.

WORKING PRESSURES - NON SHOCK

NOM. RATING	MEDIA	1/2" to 2"	15 mm to 50 mm
CLASS 300	STEAM	450 PSI @ 650°F	3104 KPa @ 343°C
	W.O.G.	640 PSI @ 100°F	4414 KPa @ 38°C

Style BDI

Y-Strainer, Class 300 NPT

Ductile Iron (ASTM A 536, Grade 65-45-12)

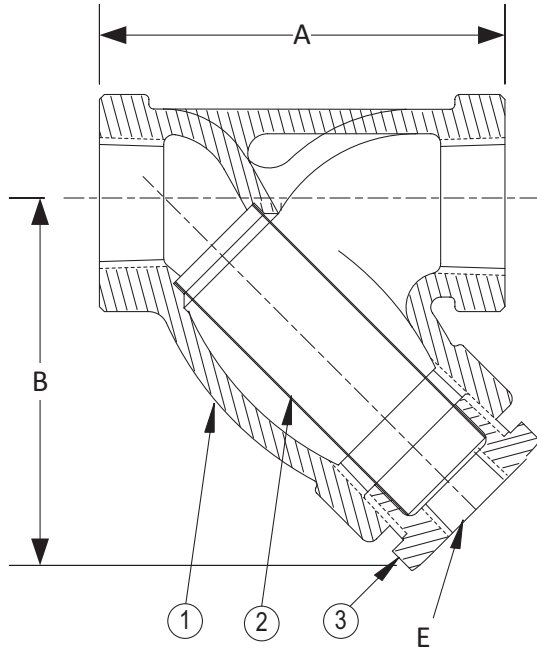

PARTS LIST

ITEM	DESCRIPTION	MATERIAL
1	Body	Ductile Iron (ASTM A 536, Grade 65-45-12)
2	Screen	Stainless Steel (304)
3	Bushing	Ductile Iron

Optional: Blow-off Plug, Malleable Iron.

STANDARD SCREENS SUPPLIED

SIZE		SCREEN PERFORATION					
		FOR LIQUID		OPEN	FOR STEAM		
in	mm	in	mm	AREA	in	mm	AREA
1/2 to 2	15 to 50	20 MESH STAINLESS STEEL				49%	

Options: Other meshes, perforations, and screen materials are available.

SIZE		DIMENSIONS						WEIGHTS	
		A		B		E			
in	mm	in	mm	in	mm	in	mm	lbs	kgs
1/2	15	3	76	2-5/8	67	3/8	10	2	0.9
3/4	20	4	102	3-5/8	92	1/2	15	3	1.4
1	25	4-7/8	124	4-1/2	114	3/4	20	4.5	2.0
1-1/4	32	5-1/8	130	4-3/4	121	3/4	20	6	2.7
1-1/2	40	5-3/4	146	4-7/8	124	1	25	8	3.6
2	50	7-1/4	184	5-3/4	146	1-1/4	32	15.5	7.0

[†]This table reflects only the nearest metric equivalents.

Dimensions and weights are for reference only. When required, request certified drawings.

Face to face values have a tolerance in compliance with ASME B16.3.

FLOW COEFFICIENTS

Size	C _v	Size	C _v	Size	C _v
1/2"	9.5	1"	30	1-1/2"	61
3/4"	18.7	1-1/4"	44.9	2"	98

TOTAL SCREEN AREA

Size	(in ²)	Size	(in ²)	Size	(in ²)
1/2"	5.50	1"	15.22	1-1/2"	23.37
3/4"	8.59	1-1/4"	18.69	2"	36.23

*See DETERMINING RATIOS on page S5 of the Strainer Information Section for calculating NET FREE AREA of the screen to inside pipe area.

Tensile Strength: 60/80,000 PSI
 Yield Strength: 45/60,000 PSI
 Elongation: 10/30%

Certified Dimensional Drawings are Available Upon Request.

PRESSURE DROP CHART

NPT “Y” Pattern Strainers (Styles B, BDI, E150, F150, F300, SB, SB7, SSB and SSB7)

This pressure drop chart is based on the flow of clean water through the Keckley “Y” strainers listed above with screen perforations ranging from 3/64” through 1/8” and is additionally for use with those units equipped with a 20 mesh screen as standard.

TO USE CHARTS:

Find your desired rate of flow (GPM) on the left hand side of the chart. Follow its corresponding horizontal line to the point where it intersects the diagonal line indicating the strainer pipe size. From this point of intersection, follow the vertical line down to the bottom of the chart to determine the approximate pressure drop.

CORRECTION FACTORS:

For finer mesh screens that are backed with a perforated sheet, multiply the pressure drops shown at right by the following:

40 mesh	x 1.2
60 mesh	x 1.4
80 mesh	x 1.6
100 mesh	x 1.7
150 mesh	x 1.8
200 mesh	x 2.0

