

# Style SB

Y-Strainer

Carbon Steel (ASTM A 216, Grade WCB)

1500 lb. Threaded

1500 lb. Socket Weld



## Cast Carbon Steel Y-Strainer

### APPLICATIONS

Steam, water, oil or gas where protection from foreign matter in a pipeline is required.

### CONSTRUCTION

The Keckley Style SB strainers are constructed from rugged carbon steel castings that are machined to exacting specifications.

Socket Weld bore is in compliance with ASME B16.11 unless otherwise specified.

### FEATURES

The Keckley Style SB strainer features a machined groove in the body and cap for proper alignment and to ensure accurate reseating when servicing is required. The gasket is 304 stainless steel spiral wound and is compressed between the body and cover (for maximum strength and durability) and designed for both high pressure and high temperature service. The cover is not supplied with a blow-off hole.

### SCREENS

Standard perforated 304 stainless steel screens are spot welded along the seam for maximum strength. Different size perforations and meshes are available in stainless steel, monel, and brass to meet specific media requirements. If media is not indicated, screens for *liquid* will be supplied.

### SELF CLEANING

**Warning:** See Maintenance Instructions on page **S6** of the Strainer Information Section for additional precautions and detailed information on servicing the strainer.

### WORKING PRESSURES - NON SHOCK

NOM. RATING	MEDIA	1/2" to 3"	15 mm to 80 mm
1500# (THREADED & SOCKET WELD)	STEAM	1500 PSI @ 838°F	10346 KPa @ 448°C
	W.O.G.	3705 PSI @ 100°F	25553 KPa @ 38°C

# Style SB

## Y-Strainer, 1500 lb. Threaded & Socket Weld Carbon Steel (ASTM A 216, Grade WCB)

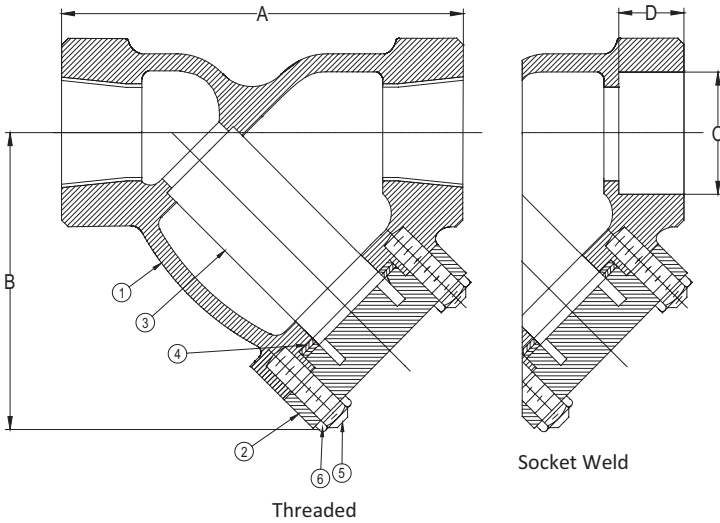

**PARTS LIST**

ITEM	DESCRIPTION	MATERIAL
1*	Body	Carbon Steel (ASTM A 216, Grade WCB)
2	Cover	Carbon Steel (ASTM A 216, Grade WCB)
3	Screen	Stainless Steel (304)
4	Gasket	Spiral Wound Stainless Steel (304)
5	Studs	Carbon Steel (ASTM A 193, Grade B16)
6	Nuts	Carbon Steel (ASTM A 194, Grade 4)

\*Optional Body Materials Available in LCB, WC6, and WC9.

**STANDARD SCREENS SUPPLIED**

SIZE		SCREEN PERFORATION					
		FOR LIQUID		OPEN AREA	FOR STEAM		OPEN AREA
in	mm	in	mm		in	mm	
1/2 to 3	15 to 80	1/16	1.6	30%	3/64	1.2	33%

Standard screens supplied are for **liquid service**, unless otherwise specified. Options: Other perforations, meshes, and screen materials are available.

SIZE		DIMENSIONS								WEIGHTS	
		A		B		C		D			
in	mm	in	mm	in	mm	in	mm	in	mm	lbs	kgs
1/2	15	3-15/16	100	3	76.2	0.855	22	3/8	10	10	5
3/4	20	4-5/16	109.5	3-3/4	95.3	1.065	27	1/2	13	12	5
1	25	6	152.4	5-3/4	146	1.330	34	1/2	13	15	7
1-1/4	32	8-1/4	209.5	5-1/2	139.7	1.675	43	1/2	13	22	10
1-1/2	40	8-1/4	209.5	5-1/2	139.7	1.915	49	1/2	13	22	10
2	50	9-5/16	236.2	9-1/4	235	2.406	61	5/8	16	30	14
2-1/2	65	12	304.8	10-1/2	266.7	2.906	74	5/8	16	50	23
3	80	12	304.8	10-1/2	266.7	3.535	90	5/8	16	50	23

<sup>†</sup>This table reflects only the nearest metric equivalents. Dimensions and weights are for reference only. When required, request certified drawings. Face to face values for threaded strainers have a tolerance in compliance with ASME B16.34 and socket weld strainers have a tolerance in compliance with ASME B16.11.

**FLOW COEFFICIENTS**

Size	C <sub>v</sub>	Size	C <sub>v</sub>	Size	C <sub>v</sub>
1/2"	9	1-1/4"	45	2-1/2"	129
3/4"	18	1-1/2"	60	3"	170
1"	30	2"	98		

**TOTAL SCREEN AREA**

Size	(in <sup>2</sup> )	Size	(in <sup>2</sup> )	Size	(in <sup>2</sup> )
1/2"	5.97	1-1/4"	27.94	2-1/2"	77.80
3/4"	9.73	1-1/2"	27.94	3"	79.48
1"	17.55	2"	38.08		

\*See DETERMINING RATIOS on page S5 of the Strainer Information Section for calculating NET FREE AREA of the screen to inside pipe area.

**PRESSURE vs. TEMPERATURE CHART**

1500# Threaded & Socket Weld Carbon Steel (ASTM A 216, Grade WCB)

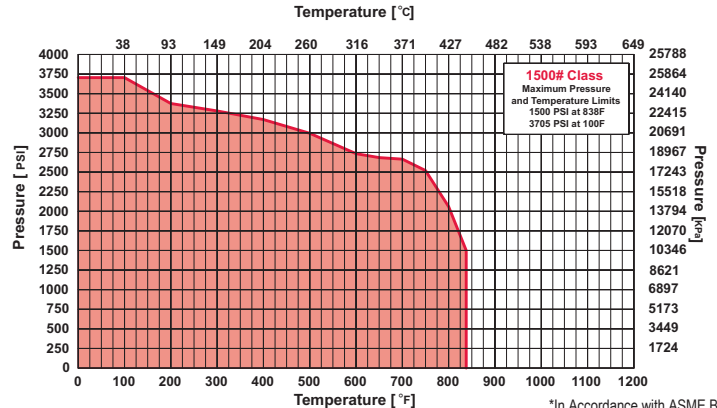

<sup>†</sup>In Accordance with ASME B16.34

# PRESSURE DROP CHART

## Threaded “Y” Pattern Strainers (Styles B, BDI, E150, F150, F300, SB, SB7, SSB and SSB7)

This pressure drop chart is based on the flow of clean water through the Keckley “Y” strainers listed above with screen perforations ranging from 3/64” through 1/8” and is additionally for use with those units equipped with a 20 mesh screen as standard.

### TO USE CHARTS:

Find your desired rate of flow (GPM) on the left hand side of the chart. Follow its corresponding horizontal line to the point where it intersects the diagonal line indicating the strainer pipe size. From this point of intersection, follow the vertical line down to the bottom of the chart to determine the approximate pressure drop.

### CORRECTION FACTORS:

For finer mesh screens that are backed with a perforated sheet, multiply the pressure drops shown at right by the following:

40 mesh	x 1.2
60 mesh	x 1.4
80 mesh	x 1.6
100 mesh	x 1.7

