

Style SSA-A2

Y-Strainer, 600 lb. Flanged

Cast Alloy 20 (ASTM A 351, Grade CN7M)

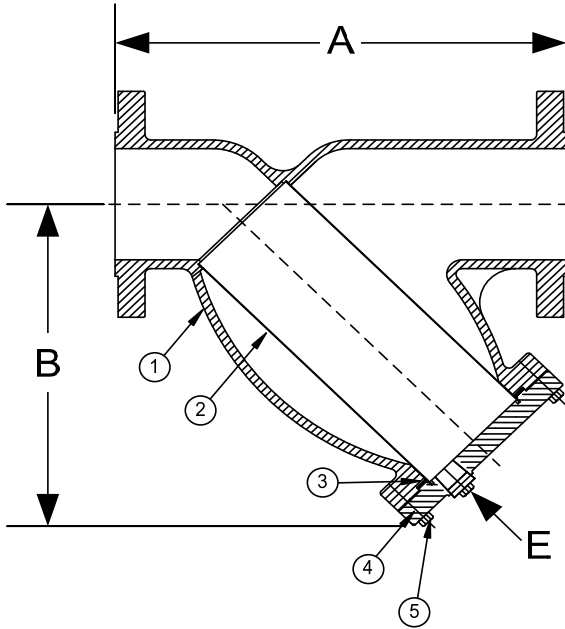

PARTS LIST

ITEM	DESCRIPTION	MATERIAL
1*	BODY	CAST ALLOY 20 (ASTM A 351, GRADE CN7M)
2	SCREEN	STAINLESS STEEL (304)
3	GASKET	SPIRAL WOUND STAINLESS STEEL (304)
4	COVER	CAST ALLOY 20 (ASTM A 351, GRADE CN7M)
5	HEX HEAD CAP SCREW	STAINLESS STEEL (ASTM A 193, GRADE B8)

Optional: Blow-off Plug, Stainless Steel (304)

*Optional Body Materials Available in 304 and 400 Series SS, Hastelloy, Inconel, Monel and Stellite.

STANDARD SCREENS SUPPLIED

SIZE		SCREEN GAGE	SCREEN PERFORATION					
in	mm		FOR STEAM		FOR LIQUID		OPEN AREA	
			in	mm	OPEN AREA	in		mm
1/2 to 4	15 to 100	28	3/64	1.2	33%	1/16	1.6	30%
5 to 10	50 to 250	22	3/64	1.2	33%	1/8	3.2	43%
12	300	22	1/16	1.6	30%	1/8	3.2	43%

Standard screens supplied are for **steam service**, unless otherwise specified.

Options: Other perforations, meshes, and screen material are available.

SIZE		DIMENSIONS						WEIGHTS	
		A		B		E			
in	mm	in	mm	in	mm	in	mm	lbs	kgs
1/2	15	6-5/8	168	3-1/2	89	3/8	10	6	3
3/4	20	8-3/8	213	3-3/4	95	1/2	15	12	5
1	25	8-3/8	213	3-3/4	95	1/2	15	12	5
1-1/4	32	10-1/8	257	5-1/2	140	1/2	15	19	9
1-1/2	40	10-1/4	260	5-1/2	140	1/2	15	24	11
2	50	11	279	7	178	1/2	15	32	15
2-1/2	65	12	305	8-1/4	210	1	25	50	23
3	80	13-1/2	343	9-1/4	235	1	25	70	32
4	100	18	457	12-1/2	318	1-1/2	40	134	61
5	125	22-1/4	565	15	381	2	50	254	115
6	150	25-5/8	651	20	508	2	50	364	165
8	200	31-3/4	806	24	610	2	50	655	297
10	250	37-3/4	959	28-1/2	724	2	50	1090	494
12	300	45-1/2	1156	34-1/2	876	2	50	1558	707

Larger sizes are available upon request.

† This table reflects only the nearest metric equivalents.

Certified Dimensional Drawings are Available Upon Request.

PRESSURE DROP CHART

Flanged "Y" Pattern Strainers (Styles SA, SA-7, SSA and SSA-7)

This pressure drop chart is based on the flow of clean water through the Keckley "Y" strainers listed above with screen perforations ranging from 3/64" through 1/8".

TO USE CHARTS:

Find your desired rate of flow (GPM) on the left hand side of the chart. Follow its corresponding horizontal line to the point where it intersects the diagonal line indicating the strainer pipe size. From this point of intersection, follow the vertical line down to the bottom of the chart to determine the approximate pressure drop.

CORRECTION FACTORS:

For finer mesh screens that are backed with a perforated sheet, multiply the pressure drops shown at right by the following:

- 40 mesh x 1.2
- 60 mesh x 1.4
- 80 mesh x 1.6
- 100 mesh x 1.7

