

DRAWING NO.
AL XXXXX

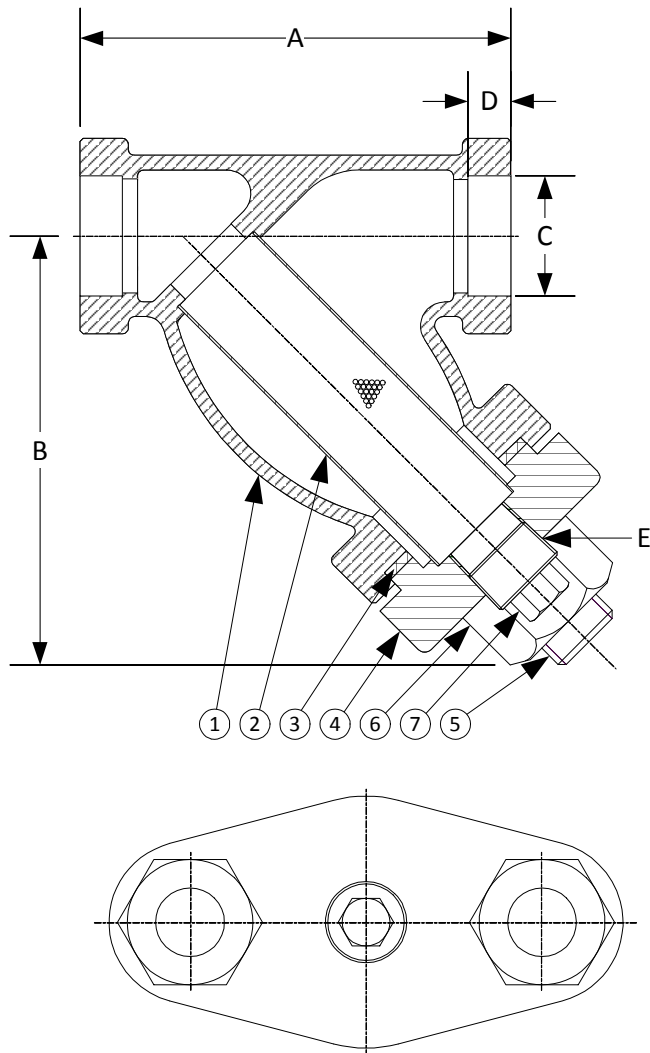

BODY PRESSURE & TEMPERATURE RATINGS - NON SHOCK		
NOM. RATING	MEDIA	1/4" to 3"
600# (SOCKET WELD)	STEAM	600 PSI @ 838°F
	W.O.G.	1480 PSI @ 100°F

PARTS LIST		
ITEM	DESCRIPTION	MATERIAL
1	BODY	CAST CHROME-MOLY (ASTM A 217, GRADE WC9)
2	SCREEN	STAINLESS STEEL (304)
3	GASKET	SPIRAL WOUND STAINLESS STEEL (304) - WITH GRAPHITE FILLER
4	CAP	CAST CHROME-MOLY (ASTM A 217, GRADE WC9)
5	STUD	CARBON STEEL (ASTM A 193, GRADE B7)
6	NUT	CARBON STEEL (ASTM A 194, GRADE 2H)
7	PLUG	STAINLESS STEEL (304)

Product Number†	SIZE	DIMENSIONS					COVER		WEIGHT
		A	B	C	D	E	No. of Bolts	Size of Bolts	
1/45SWY-C9045P34-GB	1/4	3	2-1/2	.555	3/8	1/4	2	3/8-16 x 1-1/2	3
3/85SWY-C9045P34-GB	3/8	3	2-1/2	.690	3/8	1/4	2	3/8-16 x 1-1/2	3
1/25SWY-C9045P34-GB	1/2	3-7/8	3-1/4	.855	3/8	1/4	2	3/8-16 x 1-1/2	4
3/45SWY-C9045P34-GB	3/4	4-1/4	4-1/4	1.065	1/2	3/8	2	1/2-13 x 2-1/4	5
15SWY-C9045P34-GB	1	4-15/16	4-5/8	1.330	1/2	1/2	2	5/8-11 x 2-5/8	7
11/45SWY-C9045P34-GB	1-1/4	5-5/8	5-1/2	1.675	1/2	3/4	2	5/8-11 x 2-3/4	11
11/25SWY-C9045P34-GB	1-1/2	6-1/4	6-1/4	1.915	1/2	3/4	2	7/8-9 x 3-1/8	16
25SWY-C9045P34-GB	2	7-1/2	7-1/4	2.406	5/8	1	2	1-8 x 3-1/2	22
21/25SWY-C9045P34-GB	2-1/2	12	9-3/8	2.906	5/8	1-1/4	2	1-1/8-7 x 4-1/8	43
35SWY-C9045P34-GB	3	12	9-3/8	3.535	5/8	1-1/4	2	1-1/8-7 x 4-1/8	43

†See "Style SB-7BC Product Number Configuration" for additional options.

STANDARD SCREENS SUPPLIED

SIZE	SCREEN GAGE	SCREEN PERFORATION			
		FOR STEAM	OPEN AREA	FOR LIQUID	OPEN AREA
in		in		in	
1/4 to 3	26	3/64	33%	1/16	30%

Standard screens supplied are for **steam service**, unless otherwise specified.
Options: Other meshes, perforations, and screen materials are available.

KECKLEY

3400 CLEVELAND SKOKIE ILLINOIS

DRAWING NO.
AL XXXXX

DIMENSIONAL ASSEMBLY

PART NO.

1/4" to 3" 600# Socket Weld Style SB-7BCC9

SCALE: NTS

DATE: 07/01/2011

MAT'L: Cast Chrome-Moly

REQ. ---

DR. BY DSF