

DRAWING NO.  
AL 90260

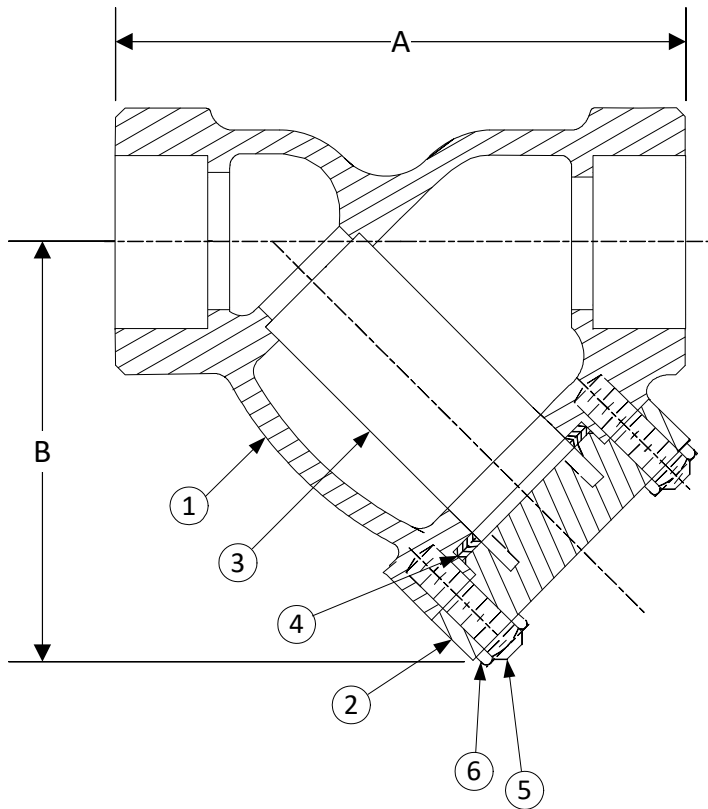

BODY PRESSURE & TEMPERATURE RATINGS – NON SHOCK		
NOM. RATING	MEDIA	1/2" to 3"
1500# (Socket Weld)	STEAM	1500 PSI @ 838°F
	W.O.G.	3705 PSI @ 100°F

PARTS LIST		
ITEM	DESCRIPTION	MATERIAL
1	BODY	CARBON STEEL (ASTM A 216, GRADE WCB)
2	COVER	CARBON STEEL (ASTM A 216, GRADE WCB)
3	SCREEN	STAINLESS STEEL (304)
4	GASKET	SPIRAL WOUND STAINLESS STEEL (304) WITH GRAPHITE FILLER
5	STUDS	CARBON STEEL (ASTM A 193, GRADE B16)
6	NUTS	CARBON STEEL (ASTM A 194, GRADE 4)

Product Number†	SIZE	DIMENSIONS (in)		COVER		WEIGHT (lbs)
		A	B	No. of Bolts	Size of Bolts	
1/27SWY-CS062P34-GB	1/2	3-15/16	3	4	1/2-13 x 1-7/8	10
3/47SWY-CS062P34-GB	3/4	4-1/4	3-3/4	4	5/8-11 x 2	12
17SWY-CS062P34-GB	1	6	5-3/4	4	3/4-10 x 2-1/2	15
11/47SWY-CS062P34-GB	1-1/4	8-1/4	5-1/2	4	5/8-11 x 2-3/4	22
11/27SWY-CS062P34-GB	1-1/2	8-1/4	5-1/2	4	5/8-11 x 2-3/4	22
27SWY-CS062P34-GB	2	9-5/16	9-1/4	4	5/8-11 x 3-1/4	30
21/27SWY-CS062P34-GB	2-1/2	12	10-1/2	4	7/8-9 x 4	50
37SWY-CS062P34-GB	3	12	10-1/2	4	7/8-9 x 4	50

†See "Style SB Product Number Configuration" for additional options.  
Face to face values tolerance in compliance with ASME B16.11.

STANDARD SCREENS SUPPLIED

SIZE	SCREEN PERFORATION			
	FOR LIQUID	OPEN AREA	FOR STEAM	OPEN AREA
in	in		in	
1/4 to 3	1/16	30%	3/64"	33%

Standard screens supplied are for **liquid service**, unless otherwise specified.  
Options: Other meshes, perforations, and screen materials are available.

 3400 CLEVELAND SKOKIE ILLINOIS		DRAWING NO. AL 90260
		PART NO.
DIMENSIONAL ASSEMBLY		SCALE: NTS
1/2" to 3" 1500# Socket Weld Style SB		DATE: 09/21/2020
MAT'L: Cast Carbon Steel	REQ. ---	DR. BY DSF