

DRAWING NO.  
AL 90470C9

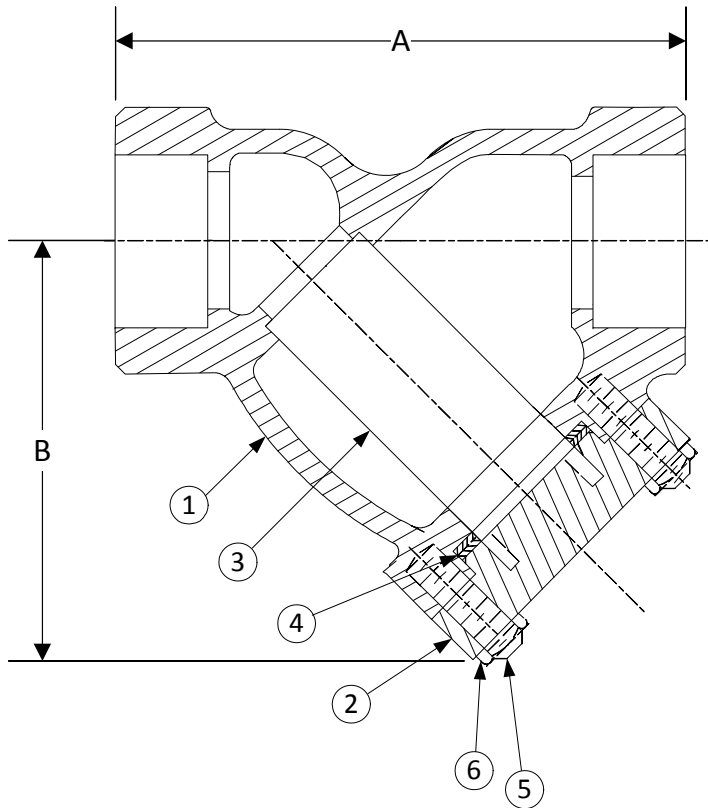

BODY PRESSURE & TEMPERATURE RATINGS - NON SHOCK		
NOM. RATING	MEDIA	1/2" to 3"
1500# (Socket Weld)	STEAM	1500 PSI @ 1125°F
	W.O.G.	3600 PSI @ 100°F

PARTS LIST		
ITEM	DESCRIPTION	MATERIAL
1	BODY	CAST CHROME-MOLY (ASTM A 217, GRADE WC9)
2	COVER	CAST CHROME-MOLY (ASTM A 217, GRADE WC9)
3	SCREEN	STAINLESS STEEL (304)
4	GASKET	SPIRAL WOUND STAINLESS STEEL (304) WITH GRAPHITE FILLER
5	STUDS	STAINLESS STEEL (ASTM A 193, GRADE B8)
6	NUTS	STAINLESS STEEL (ASTM A 194, GRADE 8)

Product Number†	SIZE	DIMENSIONS (in)		COVER		WEIGHT (lbs)
		A	B	No. of Bolts	Size of Bolts	
1/27SWY-C9033P34-GB	1/2	3-15/16	3	4	1/2-13 x 1-7/8	10
3/47SWY-C9033P34-GB	3/4	4-1/4	3-3/4	4	5/8-11 x 2	12
17SWY-C9033P34-GB	1	6	5-3/4	4	3/4-10 x 2-1/2	15
11/47SWY-C9033P34-GB	1-1/4	8-1/4	5-1/2	4	5/8-11 x 2-3/4	22
11/27SWY-C9033P34-GB	1-1/2	8-1/4	5-1/2	4	5/8-11 x 2-3/4	22
27SWY-C9033P34-GB	2	9-5/16	9-1/4	4	5/8-11 x 3-1/4	30
21/27SWY-C9033P34-GB	2-1/2	12	10-1/2	4	7/8-9 x 4	50
37SWY-C9033P34-GB	3	12	10-1/2	4	7/8-9 x 4	50

†See "Style SSB Product Number Configuration" for additional options.

STANDARD SCREENS SUPPLIED

SIZE in	SCREEN GAGE	SCREEN PERFORATION			
		FOR STEAM in	OPEN AREA	FOR LIQUID in	OPEN AREA
1/2 to 3	26	1/32	28%	1/16	30%

Standard screens supplied are for **steam service**, unless otherwise specified.  
Options: Other meshes, perforations, and screen materials are available.

 3400 CLEVELAND SKOKIE ILLINOIS		DRAWING NO. AL 90470C9
		PART NO.
DIMENSIONAL ASSEMBLY		SCALE: NTS
1/2" to 3" 1500# Socket Weld Style SB-C9		DATE: 11/30/2016
MAT'L: Cast Chrome-Moly WC9	REQ. ---	DR. BY DSF