

DRAWING NO.
AL 90820

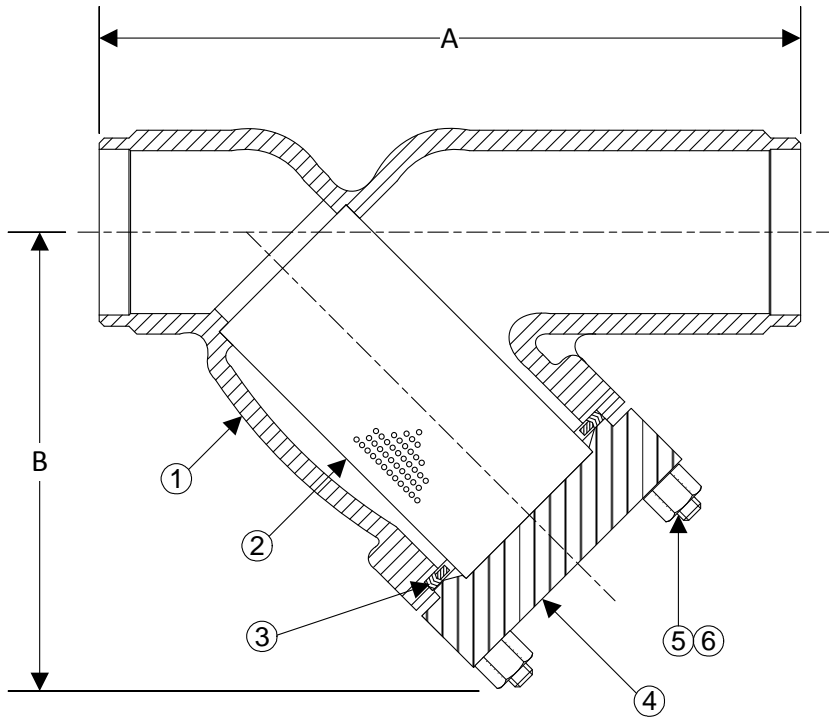

BODY PRESSURE & TEMPERATURE RATINGS - NON SHOCK		
NOM. RATING	MEDIA	1/2" to 8"
900# SCH 160 (BUTT WELD)	STEAM	710 PSI @ 1150°F
	W.O.G.	2160 PSI @ 100°F

PARTS LIST		
ITEM	DESCRIPTION	MATERIAL
1	BODY	STAINLESS STEEL (ASTM A 351, GRADE CF8M)
2	SCREEN	STAINLESS STEEL (304)
3	GASKET	SPIRAL WOUND STAINLESS STEEL (304) - WITH GRAPHITE FILLER
4	COVER	STAINLESS STEEL (ASTM A 351, GRADE CF8M)
5	STUDS	ALLOY STEEL (ASTM A 193, GRADE B)
6	HEAVY HEX NUTS	ALLOY STEEL (ASTM A 194,)

Product Number [†]	SIZE	DIMENSIONS (in)		WEIGHT (lbs)
		A	B	
1/26B9Y-36033P34-GB	1/2	7-3/8	4-1/4	20
3/46B9Y-36033P34-GB	3/4	8-3/16	4-3/4	30
16B9Y-36033P34-GB	1	9-1/16	5-3/4	52
11/46B9Y-36033P34-GB	1-1/4	12	6-3/4	65
11/26B9Y-36033P34-GB	1-1/2	12	6-3/4	65
26B9Y-36033P34-GB	2	13-15/16	7-1/2	93
21/26B9Y-36033P34-GB	2-1/2	17-1/2	10-3/4	185
36B9Y-36033P34-GB	3	17-1/2	10-3/4	185
46B9Y-36033P34-GB	4	23-3/8	15	250
66B9Y-36045P34-GB	6	31	18-7/8	560
86B9Y-36045P34-GB	8	Consult Factory	Consult Factory	Consult Factory

[†]See "Style SSA Product Number Configuration" for additional options.

STANDARD SCREENS SUPPLIED

SIZE in	SCREEN GAGE	SCREEN PERFORATION			
		FOR STEAM in	OPEN AREA	FOR LIQUID in	OPEN AREA
1/2 to 4	28	1/32	29%	1/16	30%
5 to 8	24	3/64	33%	1/8	43%

Standard screens supplied are for steam service, unless otherwise specified.
Options: Other perforations, meshes, and screen materials are available.

 3400 CLEVELAND SKOKIE ILLINOIS	DRAWING NO. AL 90820
	PART NO. 6B9Y-36
DIMENSIONAL ASSEMBLY	SCALE: NTS
1/2" to 8" 900# Butt Weld Style SSA	DATE: 09/22/2014
MAT'L: (As Noted Above)	DR. BY DSF
REQ. ---	