

Style BKF7

Basket Strainer

Nickel Aluminum Bronze

(ASTM B 148, C95800)

150 lb. Flanged



Sizes 1½" to 8"

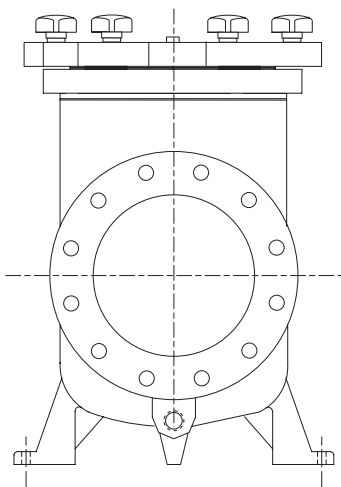

Sizes 10" & 12"

Cast Nickel Aluminum Bronze Basket Strainer

APPLICATIONS

Water, oil or gas where protection from foreign matter in a pipeline is required.

CONSTRUCTION

The Keckley Style BKF7 strainers are constructed from rugged cast nickel aluminum bronze castings and are machined to exacting specifications. These bodies have drilled flanges that are in accordance with ASME B16.24.

FEATURES

The Keckley Style BKF7 strainers feature a machined basket seat to minimize particle bypass. All sizes have knob type fasteners securing the cover flange for tool free ease in basket removal. The Keckley Style BKF7 features a Buna-N o-ring that is compressed between the body and cover for maximum strength and durability and is limited to 150°F. All Keckley Style BKF7 strainers are furnished standard with a tapped and plugged NPT connection.

BASKETS

Standard baskets are 304 stainless steel and are spot welded for maximum strength. Different size perforations and meshes are available in stainless steel, monel, and brass to meet specific media requirements.

CLEANING

Cleaning of the Style BKF7 strainer is accomplished by removing the cover and pulling out the basket. **Warning:** See Maintenance Instructions on page S6 of the Strainer Information Section for additional precautions and detailed information on servicing the strainer.

WORKING PRESSURES - NON SHOCK

NOM. RATING	MEDIA	1-1/2" to 12"	40 mm to 300 mm
150# F.F. & D. (STANDARD FLANGE)	W.O.G.	200 PSI @ 100°F	1379 KPa @ 38°C

Style BKF7

Basket Strainer, 150 lb. Flanged
Nickel Aluminum Bronze (ASTM B 148, C95800)

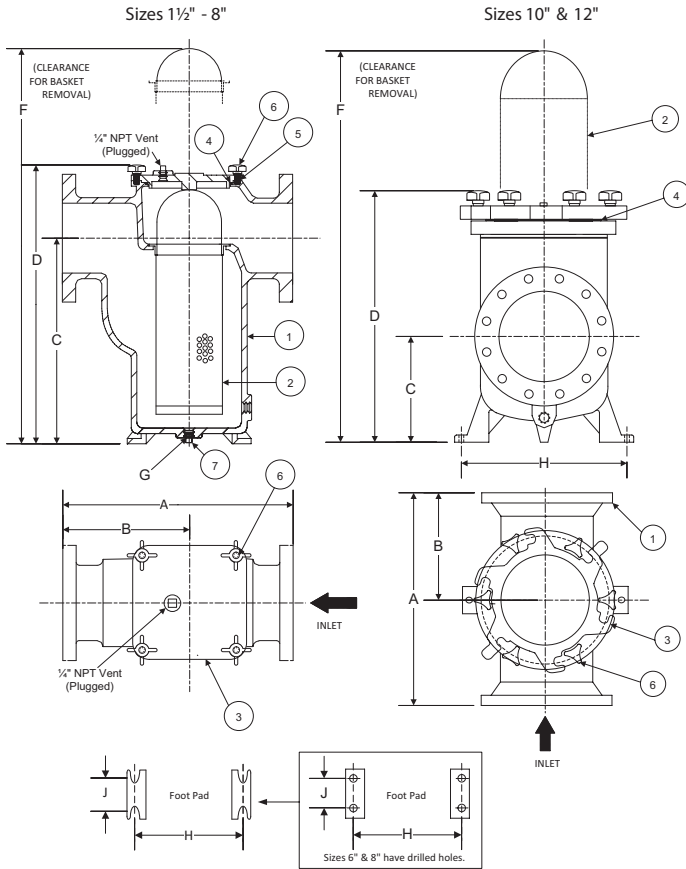

PARTS LIST

ITEM	DESCRIPTION	MATERIAL
1	Body	Nickel Aluminum Bronze (ASTM B 148, C95800)
2*	Basket	Stainless Steel (304)
3†	Cover	Nickel Aluminum Bronze (ASTM B 148, C95800)
4	O-ring	Buna-N (Max Temperature 150°F)
5	Stud	Carbon Steel (ASTM A 193, Grade B7)
6	Knob	Stainless Steel
7	Body Plug	Brass

*Denotes Spare Parts.
†Sizes 6" and larger are furnished with round covers.

STANDARD SCREENS SUPPLIED

SIZE		SCREEN PERFORATION		
		FOR LIQUID		OPEN AREA
in	mm	in	mm	
1-1/2 to 12	40 to 300	1/8	3.2	43%

Options: Other meshes, perforations, and screen materials are available.

Pipe Size		DIMENSION													
		A		B		C		D		F		G		H	
in	mm	in	mm	in	mm	in	mm	in	mm	in	mm	in	mm	in	mm
1-1/2	40	10.25	260	5.63	143	7.00	178	11.00	279	16	406	1/4	8	5.5	140
2	50	10.50	267	5.75	146	6.63	168	10.25	260	20	508	1/2	15	5.5	140
2-1/2	65	11.63	295	6.63	168	7.88	200	11.88	302	23	584	3/8	10	6.5	165
3	80	13.13	334	7.25	184	9.25	235	13.75	349	27	686	3/8	10	7.0	178
4	100	16.75	426	9.38	238	9.00	229	14.75	375	29	737	1/2	15	10.00	254
6	150	19.63	499	10.81	275	15.75	400	24.00	610	46	1168	1/2	15	10.00	254
8	200	27	686	16.00	406	27.00	686	36.187	919	61	1549	1/2	15	15.75	400
10	250	23	584	11.00	279	12.19	310	25.00	635	47	1194	--	--	19.00	483
12	300	27.25	692	13.13	334	16.75	426	31.00	787	67	1702	--	--	23.00	584

Pipe Size		DIMENSION							WEIGHT	
		J		Flow Coefficients (C _v)	Total Screen Area (in ²)	O-Ring Type	Number of Knobs	lbs		
in	mm	in	mm							
1-1/2	40	2.50	64	46	37.78	Buna-N	4	28	12.47	
2	50	2.50	64	73	60.78	Buna-N	4	39	17.63	
2-1/2	65	2.88	73	125	78.53	Buna-N	4	45	20.30	
3	80	3.13	80	180	115.33	Buna-N	4	73	33.11	
4	100	3.88	99	350	172.18	Buna-N	4	129	58.48	
6	150	5.10	127	900	352.50	Buna-N	6	237	107.50	
8	200	8.50	216	1400	1091.48	Buna-N	8	488	221.02	
10**	250	--	--	2300	486.30	Buna-N	6	379	171.57	
12**	300	--	--	3200	580.27	Buna-N	6	579	262.30	

**Mounting Hole Ø is 1" Nominal, 1" Thick.
Face to face values tolerance in compliance with ASME B16.24.

PRESSURE DROP CHART

Basket Strainers (Styles KF7 and BKF7)

This pressure drop chart is based on the flow of clean water through the Keckley strainer styles listed above with screen perforations ranging from 3/64" through 1/4".

TO USE CHARTS:

Find your desired rate of flow (GPM) on the left hand side of the chart. Follow its corresponding horizontal line to the point where it intersects the diagonal line indicating the strainer pipe size. From this point of intersection, follow the vertical line down to the bottom of the chart to determine the approximate pressure drop.

CORRECTION FACTORS:

For finer mesh baskets that are backed with a perforated sheet, multiply the pressure drops shown at right by the following:

- 40 mesh x 1.2
- 60 mesh x 1.4
- 80 mesh x 1.6
- 100 mesh x 1.7

