

DRAWING NO.  
AL 88060

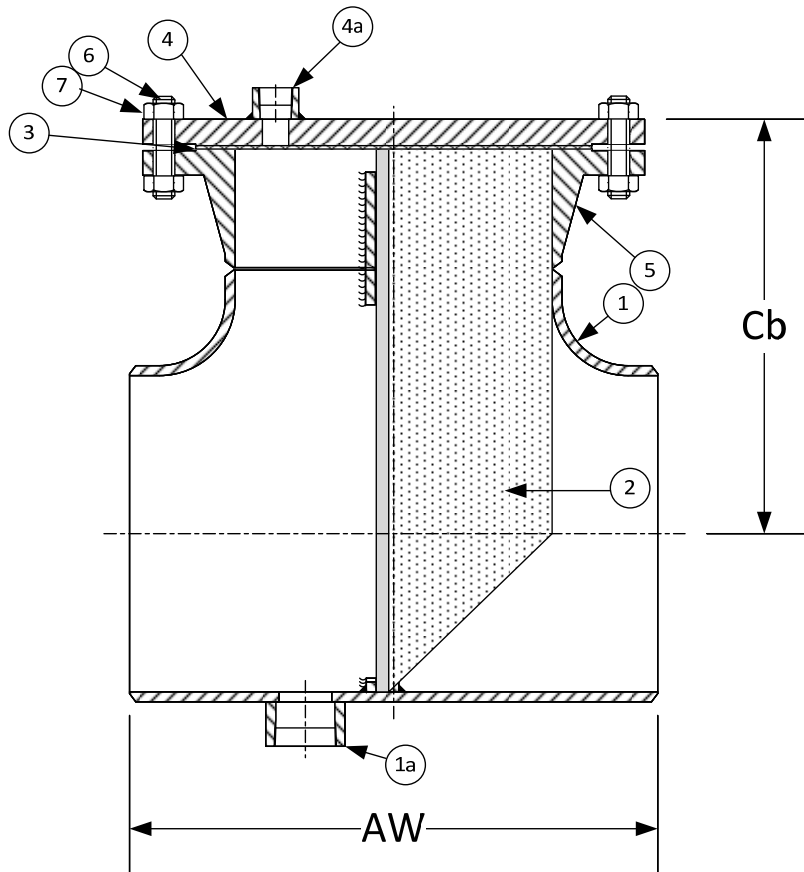

PARTS LIST		
ITEM	DESCRIPTION	MATERIAL
1	BODY	FORGED CARBON STEEL (ASTM A 234, CLASS WPB)
1a	COUPLING - HALF, 3000# NPT	FORGED CARBON STEEL (ASTM A 105)
2	BASKET	STAINLESS STEEL (304) - 1/8" PERFORATION
3	GASKET	FIBER
4	300LB RF BLIND FLANGE	FORGED CARBON STEEL (ASTM A 105)
4a	COUPLING - HALF, 3000# NPT	FORGED CARBON STEEL (ASTM A 105)
5*	300LB RFWN FLANGE	FORGED CARBON STEEL (ASTM A 105) B 16.5
6	STUDS	ALLOY STEEL (ASTM A 193, GRADE B7)
7	NUTS	ALLOY STEEL (ASTM A 194, GRADE 2H)

\*30" & Larger Flanges Are RFWN Series B.

Product Numbers <sup>†</sup>	DIMENSIONS (in)					WEIGHT (lbs)	
	SIZE	AW	Cb	Vent	Drain	Cover	Total
24BSFT-FCS125P34-FBB	2"	5	6-1/8	1/8	1/2	8	21
21/24BSFT-FCS125P34-FBB	2-1/2"	6	7	1/8	1/2	12	30
34BSFT-FCS125P34-FBB	3"	6-3/4	7-5/8	1/8	3/4	16	42
44BSFT-FCS125P34-FBB	4"	8-1/4	8-3/4	1/2	3/4	28	64
54BSFT-FCS125P34-FBB	5"	9-3/4	10-1/8	1/2	1	37	86
64BSFT-FCS125P34-FBB	6"	11-1/4	11	1/2	2	50	116
84BSFT-FCS125P34-FBB	8"	14	13	1/2	2	81	184
104BSFT-FCS125P34-FBB	10"	17	15	1/2	2	124	281
124BSFT-FCS125P34-FBB	12"	20	17-1/8	1/2	2	185	418
144BSFT-FCS125P34-FBB	14"	22	18-3/4	1/2	2	250	621
164BSFT-FCS125P34-FBB	16"	24	20	1/2	2	315	775
184BXFT-FCS125P34-FBB	18"	27	22-1/8	1/2	2	415	1095
204BXFT-FCS125P34-FBB	20"	30	23-7/8	1/2	2	515	1365
244BXFT-FCS125P34-FBB	24"	34	26-3/8	1/2	2	800	2010
304BXFT-FCS125P34-FBB	30"	44	31-7/8	1/2	2	1249	2959

<sup>†</sup>See "Style T Product Number Configuration" for additional options.

BODY PRESSURE & TEMPERATURE RATINGS - NON SHOCK	
NOM. RATING	2" to 30"
300# Butt Weld	740 PSI @ 100°F

**KECKLEY**

3400 CLEVELAND SKOKIE ILLINOIS

DRAWING NO.  
AL 88060

DIMENSIONAL ASSEMBLY

PART NO.

300lb. Butt Weld, Style T,

SCALE: NTS

Fabricated Carbon Steel Tee Strainer

DATE: 04/03/2017

MAT'L: (As Noted Above)

REQ. ---

DR. BY DSF