

DRAWING NO.

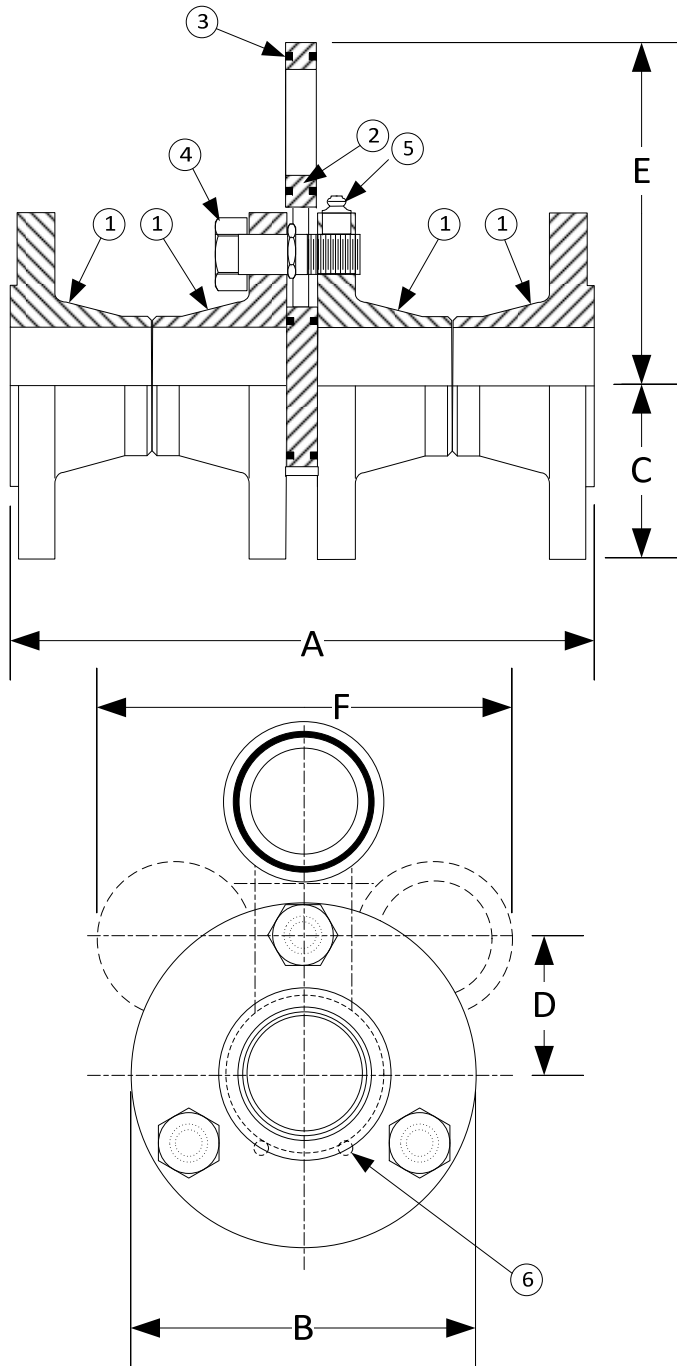

BODY PRESSURE & TEMPERATURE RATINGS – NON SHOCK

NOM. RATING	1" to 24"
150# RFWN	285 PSI @ 100°F

PARTS LIST

Item	Description	Material
1	150LB RFWN FLANGE	CARBON STEEL (ASTM A 105) B16.5
2	SPECTACLE PLATE	CARBON STEEL (ASTM A 36)
3*	O-RING	BUNA-N
4	PIVOT BOLT / SPREADER BOLT	CARBON STEEL (SAE J 429, GRADE 8)
5	GREASE FITTING (Qty. of 3)	
6	SPRING PINS	STAINLESS STEEL (304)

*Buna-n o-ring good for temperatures up to 250°F. For higher temperatures, consult factory.

Product Number†	DIMENSIONS (in)							WEIGHT (lbs)
	SIZE	A	B	C	D	E	F	
12RFRFLB-FCSCS-BCSB	1	9	4-1/4	2-1/8	1-9/16	4-3/8	5-5/8	13
11/22RFRFLB-FCSCS-BCSB	1-1/2	10	5	2-1/2	1-15/16	5-1/2	7-1/8	17
22RFRFLB-FCSCS-BCSB	2	10-3/8	6	3	2-3/8	6-3/4	8-3/4	26
21/22RFRFLB-FCSCS-BCSB	2-1/2	11-3/8	7	3-1/2	2-3/4	7-7/8	10-1/4	43
32RFRFLB-FCSCS-BCSB	3	11-3/8	7-1/2	3-3/4	3	8-5/8	11-1/4	49
42RFRFLB-FCSCS-BCSB	4	12-1/2	9	4-1/2	3-3/4	10-7/8	14-1/4	71
52RFRFLB-FCSCS-BCSB	5	14-5/8	10	5	4-1/4	10-7/8	14-1/4	94
62RFRFLB-FCSCS-BCSB	6	14-5/8	11	5-1/2	4-3/4	13-13/16	18-1/8	114
82RFRFLB-FCSCS-BCSB	8	16-5/8	13-1/2	6-3/4	5-7/8	17-3/16	22-5/8	188
102RFRFLB-FCSCS-BCSB	10	16-3/4	16	8	7-1/8	20-7/8	27-1/2	251
122RFRFLB-FCSCS-BCSB	12	18-7/8	19	9-1/2	8-1/2	25	33	414
142RFRFLB-FCSCS-BCSB	14	20-7/8	21	10-1/2	9-3/4	27-1/2	36-1/4	530
162RFRFLB-FCSCS-BCSB	16	21	23-1/2	11-3/4	10-5/8	31-1/4	41-1/4	687
182RFRFLB-FCSCS-BCSB	18	23-1/8	25	12-1/2	11-3/8	33-7/16	44-1/8	799
202RFRFLB-FCSCS-BCSB	20	24	27-1/2	13-3/4	12-1/2	36-13/16	48-5/8	976
242RFRFLB-FCSCS-BCSB	24	25-3/8	32	16	14-3/4	43-1/2	57-1/2	1387

†See "Style FLB Product Number Configuration" for additional options.

3400 CLEVELAND

SKOKIE ILLINOIS

DRAWING NO.

DIMENSIONAL ASSEMBLY

PART NO.

150Lb. Fig. Style FLB,

SCALE: NTS

Fabricated Line Blind

DATE: 07/01/2011

MAT'L: Fabricated Carbon Steel

REQ. ---

DR. BY DSF