

DRAWING NO.

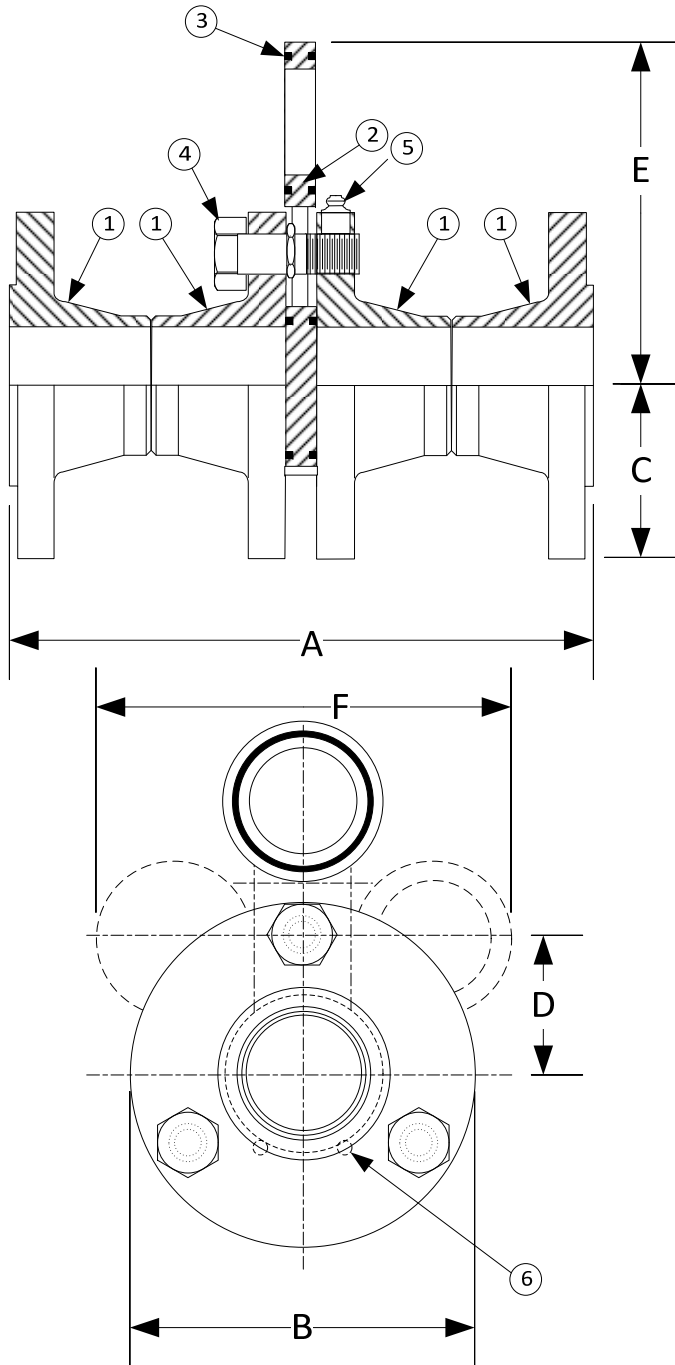

BODY PRESSURE & TEMPERATURE RATINGS - NON SHOCK	
NOM. RATING	1" to 24"
600# RFWN	1480 PSI @ 100°F

## PARTS LIST

Item	Description	Material
1	600LB RFWN FLANGE	CARBON STEEL (ASTM A 105) B16.5
2	SPECTACLE PLATE	CARBON STEEL (ASTM A 36)
3*	O-RING	BUNA-N
4	PIVOT BOLT / SPREADER BOLT	CARBON STEEL (SAE J 429, GRADE 8)
5	GREASE FITTING (Qty. of 3)	
6	SPRING PINS	STAINLESS STEEL (304)

\*Buna-n o-ring good for temperatures up to 250°F. For higher temperatures, consult factory.

Product Number†	DIMENSIONS (in)							WEIGHT (lbs)
	SIZE	A	B	C	D	E	F	
15RFRFLB-FCSCS-BCSB	1	10-3/4	4-7/8	2-5/16	1-3/4	4-7/8	6-1/4	17
11/25RFRFLB-FCSCS-BCSB	1-1/2	12	6-1/8	3-1/16	2-1/4	6-5/16	8-1/8	34
25RFRFLB-FCSCS-BCSB	2	12-1/2	6-1/2	3-1/4	2-1/2	7-1/8	9-1/4	51
21/25RFRFLB-FCSCS-BCSB	2-1/2	13-1/2	7-1/2	3-3/4	2-15/16	8-3/8	10-7/8	76
35RFRFLB-FCSCS-BCSB	3	14	8-1/4	4-1/8	3-5/16	9-1/2	12-3/8	99
45RFRFLB-FCSCS-BCSB	4	17	10-3/4	5-3/8	4-1/4	12-1/4	16	182
55RFRFLB-FCSCS-BCSB	5	19-1/4	13	6-1/2	5-1/4	12-1/4	16	308
65RFRFLB-FCSCS-BCSB	6	19-3/4	14	7	5-3/4	16-11/16	21-7/8	360
85RFRFLB-FCSCS-BCSB	8	22-1/4	16-1/2	8-1/4	6-7/8	20	26-1/4	545
105RFRFLB-FCSCS-BCSB	10	25-3/8	20	10	5-1/2	24-13/16	32-5/8	892
125RFRFLB-FCSCS-BCSB	12	26	22	11	9-5/8	28-1/8	37	1097
145RFRFLB-FCSCS-BCSB	14	27-1/2	23-3/4	11-7/8	10-3/8	29-15/16	39-1/2	1606
165RFRFLB-FCSCS-BCSB	16	29-5/8	27	13-1/2	11-7/8	34-3/4	45-3/4	2289
185RFRFLB-FCSCS-BCSB	18	30-3/4	29-1/4	14-5/8	12-7/8	37-11/16	49-5/8	2670
205RFRFLB-FCSCS-BCSB	20	31-7/8	32	16	14-1/4	41-13/16	55-1/8	3385
245RFRFLB-FCSCS-BCSB	24	34	37	18-1/2	16-1/2	48-7/16	63-7/8	4878

†See "Style FLB Product Number Configuration" for additional options.

3400 CLEVELAND

SKOKIE ILLINOIS

DRAWING NO.

DIMENSIONAL ASSEMBLY

PART NO.

600Lb. Fig. Style FLB,

SCALE: NTS

Fabricated Line Blind

DATE: 07/01/2011

MAT'L: Fabricated Carbon Steel

REQ. ---

DR. BY DSF