

## Style DD

Cast Iron (ASTM A 126, Class B)  
125 lb. Class

Carbon Steel (ASTM A 216, Grade WCB)  
150 lb. Thru 1500 lb. Class

Stainless Steel (ASTM A 351, Grade CF8M)  
150 lb. Thru 1500 lb. Class



## Style DL

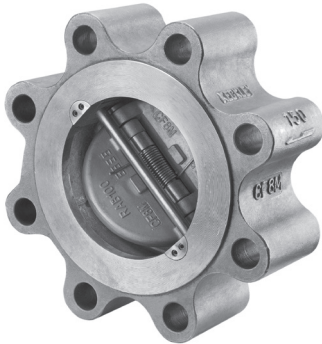

## Style DF

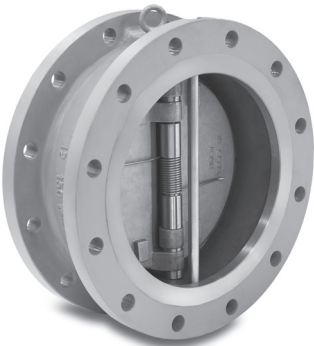

## Wafer Double Disc Check Valve

### APPLICATIONS

Flow reversal solutions for Liquid and Gas applications where protection from flow reversal in a pipeline is required

### CONSTRUCTION

Keckley Style DD wafer body double disc check valves are produced by the investment casting process. These castings are thoroughly inspected and machined to exacting specifications. Reference individual technical data pages for standard materials utilized in the construction of valve components.

### FEATURES

- A short face-to-face dimension.
- The spring loaded double disc design creates a low cracking pressure and allows for the valve discs to close prior to any flow reversal minimizing water hammer and/or surges in the media.
- Tension on the specially designed spring with extended spring legs allows the disc center section to lift off the seat prior to the outside edge opening preventing seat wear in the center “heel” section of the seating surface.
- Standard elastomeric seats can produce zero leakage when correctly specified, loaded, and installed. Metal seating surfaces are precision machined and lapped to a mirror finish to provide a long lasting seal which meets or exceeds the API 598 leakage standard.
- Retainerless design check valves have no body penetrations eliminating potential leak paths.
- Allows for interchangeability of the hinge pin and stop pin.
- Epoxy coating is standard.
- Field serviceable without the need for special tools.

### INSTALLATION

The Style DD can be installed in both vertical and horizontal applications. Contact Keckley for all downward vertical flow installations.

### ORDERING

Reference page C2 for Keckley Check Valve Product Numbers.

### WORKING PRESSURES - NON SHOCK

NOM. RATING	BODY MATERIAL	MEDIA	2" to 12"	14" to 24"
125#	CAST IRON (ASTM A 126, CLASS B)	W.O.G.	200 PSI @ 150°F	150 PSI @ 150°F
NOM. RATING	BODY MATERIAL	MEDIA	2" to 24"	
150#	CARBON STEEL (ASTM A 216, GRADE WCB)	W.O.G.	285 PSI @ 100°F	
	STAINLESS STEEL (ASTM A 351, GRADE CF8M)	W.O.G.	275 PSI @ 100°F	
NOM. RATING	BODY MATERIAL	MEDIA	2" to 24"	
300#	CARBON STEEL (ASTM A 216, GRADE WCB)	W.O.G.	740 PSI @ 100°F	
	STAINLESS STEEL (ASTM A 351, GRADE CF8M)	W.O.G.	720 PSI @ 100°F	

## Style DD

### Retainerless Wafer Body

### Double Disc Check Valve, 150 lb.

### Nickel Aluminum Bronze (ASTM B 148, C95800)

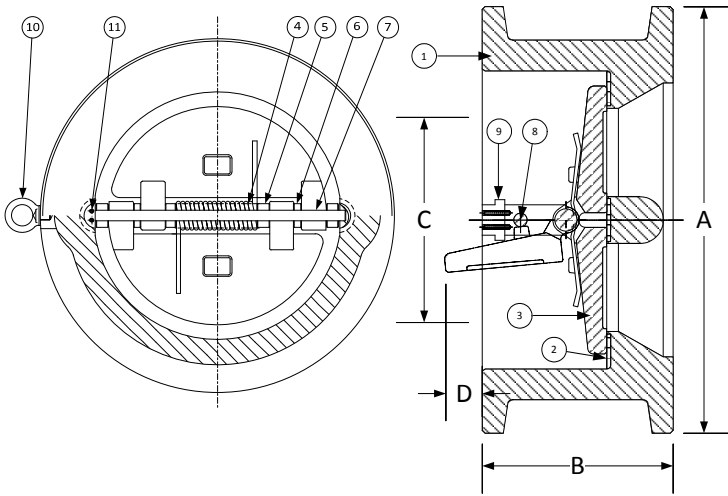
**PARTS LIST**

ITEM	DESCRIPTION	MATERIAL
1	Body	Cast Nickel Aluminum Bronze (ASTM B 148, C95800)
2	Seat	Buna-N O-Ring
3	Disc	Cast Nickel Aluminum Bronze (ASTM B 148, C95800)
4	Spring	Inconel X-750
5	Spring Plate	Stainless Steel (ASTM A 182, Grade F-316)
6	Thrust Washer	Stainless Steel (ASTM A 182, Grade F-316)
7	Hinge Pin	Stainless Steel (ASTM A 182, Grade F-316)
8	Stop Pin	Stainless Steel (ASTM A 182, Grade F-316)
9	Locating Piece	Stainless Steel (ASTM A 182, Grade F-316)
10	Lifting Lug	Carbon Steel
11	Screw	Stainless Steel (316)

 Above "Standard" Product Number - **DD2F-NA-NA1IX**

 Other Options - Reference **C2** for available materials.

SIZE		DIMENSIONS								WEIGHTS	
		A		B		C*		D			
in	mm	in	mm	in	mm	in	mm	in	mm	lbs	kgs
2	50	4-1/8	105	2-3/8	60	1-15/16	49	-	-	6	3
2-1/2	65	4-7/8	124	2-5/8	67	2-11/32	60	-	-	10	5
3	80	5-3/8	137	2-7/8	73	2-29/32	74	1/4	6	13	6
4	100	6-7/8	175	2-7/8	73	3-53/64	97	5/8	16	17	8
5	125	7-3/4	197	3-3/8	86	4-13/16	122	7/8	22	27	12
6	150	8-3/4	222	3-7/8	98	5-49/64	146	1-3/8	35	35	16
8	200	11	279	5	127	7-5/8	194	2-1/8	54	70	32
10	250	13-3/8	340	5-3/4	146	9-9/16	243	2-3/4	70	106	48
12	300	16-1/8	410	7-1/8	181	11-3/8	289	3-1/4	83	172	78
14	350	17-3/4	451	7-1/4	184	12-1/2	318	3-1/4	83	200	91
16	400	20-1/4	514	7-1/2	191	15	381	4-7/16	113	275	125
18	450	21-5/8	549	8	203	16-7/8	429	5-3/8	137	315	143
20	500	23-7/8	606	8-5/8	219	18-13/16	478	6-5/16	160	435	197
24	600	28-1/4	718	8-3/4	222	22-5/8	575	8-1/4	210	620	281
30	750	34-3/4	883	13	330	29-1/4	743	9	229	1230	558
36	900	41-1/4	1048	15-1/4	387	35	889	11-15/16	303	2017	915
42	1050	48	1219	17	432	41	1041	15	381	2800	1270
48	1200	54-1/2	1384	20-5/8	524	47	1194	16-3/4	425	3920	1778

\*Minimum companion flange bore.

 Sizes 30" and larger fit **Series A** flanges.

Seat Material	Operating Temperature**	
	°F	°C
Buna-N	-20 to 250	-29 to 121
Viton	-20 to 400	-29 to 204
EPDM	-40 to 300	-40 to 149

\*\*Subject to limitations of body material.

Applicable Standards
• Design ASME B16.24
• Testing API 598
• Conforms to API 594 & 6D
• MSS SP - 6
• MSS SP - 25
• MSS SP - 55

**FLOW COEFFICIENTS**

Size	2"	2½"	3"	4"	5"	6"
C <sub>v</sub>	48	98	170	290	495	720
Size	8"	10"	12"	14"	16"	18"
C <sub>v</sub>	1800	2600	4300	5500	7200	9400
Size	20"	24"	30"	36"	42"	48"
C <sub>v</sub>	12600	19000	37500	60000	89000	124000

# PRESSURE DROP CHART

## Wafer Double Disc Check Valve (Style DD, DL, and DF)

This pressure drop chart is based on the flow of clean water through the Keckley Double Disc Check Valve. The Keckley Style DD has a cracking pressure equal to or less than 0.3 psi when mounted horizontally. Check valves should be placed at a distance equal to 5 to 10 pipe diameters from any turbulence producing device such as elbows, pumps, etc.

**TO USE CHARTS:**

Find your desired rate of flow (GPM) on the left hand side of the chart. Follow its corresponding horizontal line to the point where it intersects the diagonal line indicating the check valve pipe size. From this point of intersection, follow the vertical line down to the bottom of the chart to determine the approximate pressure drop.

