

DRAWING NO.
AL 103000

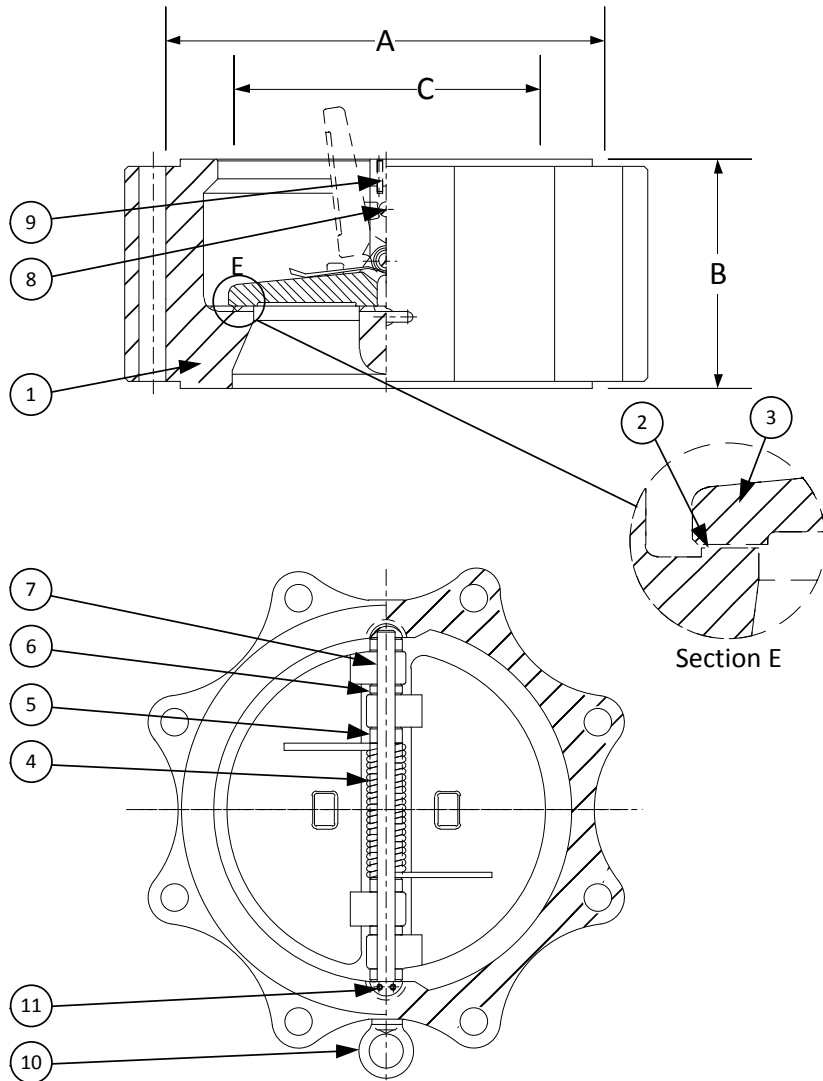

PARTS LIST

ITEM	DESCRIPTION	MATERIAL
1	BODY	BRONZE (ASTM B 62, C83600)
2	SEAT*	BRONZE (ASTM B 62, C83600)
3	DISC	STAINLESS STEEL (ASTM A 351, GRADE CF8M)
4	SPRING	INCONEL X-750
5	SPRING PLATE	STAINLESS STEEL (ASTM A 182, GRADE F-316)
6	THRUST WASHER	STAINLESS STEEL (ASTM A 182, GRADE F-316)
7	HINGE PIN	STAINLESS STEEL (ASTM A 182, GRADE F-316)
8	STOP PIN	STAINLESS STEEL (ASTM A 182, GRADE F-316)
9	LOCATING PIECE	STAINLESS STEEL (ASTM A 182, GRADE F-316)
10	LIFTING LUG	CARBON STEEL
11	SCREW	STAINLESS STEEL (316)

*Other Seat Options Available in Metal (Same as Disc), 316LSS Overlay, and 410SS Overlay.

PRODUCT NUMBER†	SIZE	DIMENSIONS			WEIGHT
		A	B	C*	
2DL2F-B2-362IX	2	4-1/8	2-3/8	1-15/16	18
21/2DL2F-B2-362IX	2-1/2	4-7/8	2-5/8	2-11/32	22
3DL2F-B2-362IX	3	5-3/8	2-7/8	2-29/32	30
4DL2F-B2-362IX	4	6-7/8	2-7/8	3-53/64	44
5DL2F-B2-362IX	5	7-3/4	3-3/8	4-13/16	51
6DL2F-B2-362IX	6	8-3/4	3-7/8	5-49/64	84
8DL2F-B2-362IX	8	11	5	7-1/2	91
10DL2F-B2-362IX	10	13-3/8	5-3/4	9-7/16	156
12DL2F-B2-362IX	12	16-1/8	7-1/8	11-1/4	252
14DL2F-B2-362IX	14	17-3/4	7-1/4	12-5/8	291
16DL2F-B2-362IX	16	20-1/4	7-1/2	14-11/16	464
18DL2F-B2-362IX	18	21-5/8	8	16-9/16	431
20DL2F-B2-362IX	20	23-7/8	8-5/8	18-7/16	501
24DL2F-B2-362IX	24	28-1/4	8-3/4	21-5/8	682
30DL2F-B2-362IX	30	34-3/4	12	28-7/16	1321
36DL2F-B2-362IX	36	41-1/4	14-1/2	34-3/8	1898
42DL2F-B2-362IX	42	48	17	40-9/16	3236
48DL2F-B2-362IX	48	54-1/2	20-5/8	44-3/16	4899

*Minimum companion flange bore.

Available with thru-hole bolting or threaded bolt holes.

†See "Style DL Product Number Configuration" for additional options.

BODY PRESSURE & TEMPERATURE RATINGS – NON SHOCK		
NOM. RATING	MEDIA	2" to 48"
150# (WAFER LUG)	W.O.G.	225 PSI @ 150°F

APPLICABLE STANDARDS

• Design ASME B16.24	• MSS SP – 6
• Conform to API 594 & 6D	• MSS SP – 25
• Testing API 598	• MSS SP – 55

KECKLEY

3400 CLEVELAND SKOKIE ILLINOIS

DRAWING NO.
AL 103000

DIMENSIONAL ASSEMBLY

PART NO.
DL2F-B2-362IX

150# Retainerless Wafer Lug Body

SCALE: NTS

Double Disc Check Valve

DATE: 07/01/2011

MAT'L: Cast Bronze

REQ. ---

DR. BY DSF