

Style DD

Cast Iron (ASTM A 126, Class B)
125 lb.

Carbon Steel (ASTM A 216, Grade WCB)
150 lb. Thru 1500 lb.

Stainless Steel (ASTM A 351, Grade CF8M)
150 lb. Thru 1500 lb.



Style DL



Style DF



Wafer Double Disc Check Valve

APPLICATIONS

Liquid or gas where protection from flow reversal in a pipeline is required.

CONSTRUCTION

The Keckley Wafer Double Disc Check Valves are constructed from rugged castings that are machined to exacting specifications. Reference individual technical data pages for standard disc, shaft, spring, and elastomer seat.

FEATURES

- A short face-to-face dimension.
- Lighter weight, by 80-90% than non-conventional full-body check valves.
- Spring-loaded, double disc design has a low cracking pressure.
- The tension spring performs a lifting motion on the disc to prevent excessive wear on the “heel” area of the elastomer seat.
- The independent, dual shaft design allows interchangeability of shafts. The stop shaft stabilizes the discs during high flow rates.
- Epoxy coating is standard.
- Field serviceable without the need for special tools.

INSTALLATION

The Keckley Wafer Double Disc Check Valves are used in both vertical and horizontal applications. For horizontal flow applications the shaft should be vertically oriented. Contact Keckley for downward vertical flow installations.

ORDERING

Reference page [C2](#) for Keckley Check Valve Product Numbers.

WORKING PRESSURES – NON SHOCK

NOM. RATING	BODY MATERIAL	MEDIA	2" to 12"	14" to 24"
125#	CAST IRON (ASTM A 126, CLASS B)	W.O.G.	200 PSI @ 150°F	150 PSI @ 150°F
NOM. RATING	BODY MATERIAL	MEDIA	2" to 24"	
150#	CARBON STEEL (ASTM A 216, GRADE WCB)	W.O.G.	285 PSI @ 100°F	
	STAINLESS STEEL (ASTM A 351, GRADE CF8M)	W.O.G.	275 PSI @ 100°F	
NOM. RATING	BODY MATERIAL	MEDIA	2" to 24"	
300#	CARBON STEEL (ASTM A 216, GRADE WCB)	W.O.G.	740 PSI @ 100°F	
	STAINLESS STEEL (ASTM A 351, GRADE CF8M)	W.O.G.	720 PSI @ 100°F	

Style DF

**Retainerless Wafer Double Flange Body
 Double Disc Check Valve, 150 lb.
 Bronze (ASTM B 62, C83600)**

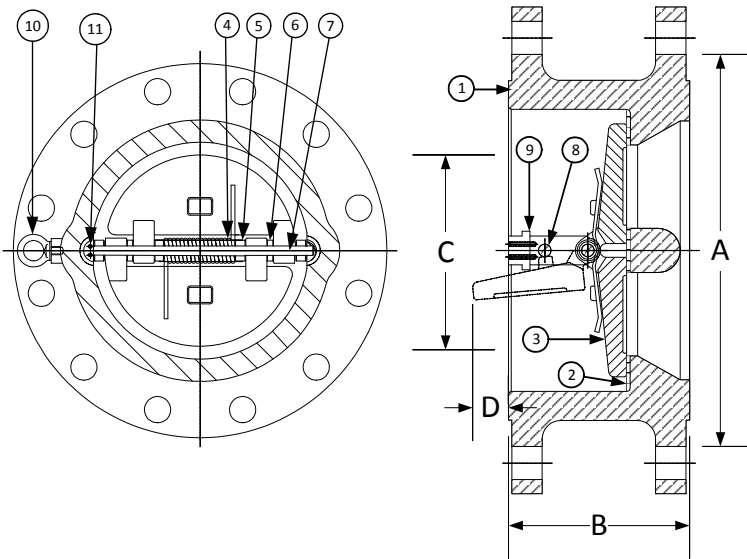
PARTS LIST

ITEM	DESCRIPTION	MATERIAL
1	Body	Cast Bronze (ASTM B 62, C83600)
2	Seat	Buna-N O-Ring
3	Disc	Stainless Steel (ASTM A 351, Grade CF8M)
4	Spring	Inconel X-750
5	Spring Plate	Stainless Steel (ASTM A 182, Grade F-316)
6	Thrust Washer	Stainless Steel (ASTM A 182, Grade F-316)
7	Hinge Pin	Stainless Steel (ASTM A 182, Grade F-316)
8	Stop Pin	Stainless Steel (ASTM A 182, Grade F-316)
9	Locating Piece	Stainless Steel (ASTM A 182, Grade F-316)
10	Lifting Lug	Carbon Steel
11	Screw	Stainless Steel (316)

Above "Standard" Product Number – **DF2F-B2-3611X**

Other Options - Reference **C2** for available materials.

SIZE		DIMENSIONS						WEIGHTS	
		A		B		C*			
in	mm	in	mm	in	mm	in	mm	lbs	kgs
8	200	11	279	5	127	7-5/8	194	93	42
10	250	13-3/8	340	5-3/4	146	9-9/16	243	189	86
12	300	16-1/8	410	7-1/8	181	11-3/8	289	308	140
14	350	17-3/4	451	7-1/4	184	12-1/2	318	352	160
16	400	20-1/4	514	7-1/2	191	15	381	496	225
18	450	21-5/8	549	8	203	16-7/8	428	551	250
20	500	23-7/8	606	8-5/8	219	8-7/8	480	661	300
24	600	28-1/4	718	8-3/4	222	22-5/8	575	860	389
30	750	34-3/4	883	12	305	29-1/4	743	1512	687
36	900	41-1/4	1048	14-1/2	368	35	889	2525	1145
42	1050	48	1219	17	432	41	1041	4163	1888
48	1200	54-1/2	1384	20-5/8	524	47	1194	5880	2667

*Minimum companion flange bore.

Available with thru-hole bolting or threaded bolt holes.

Sizes 30" and larger fit **Series A** flanges.

Seat Material	Operating Temperature**	
	°F	°C
Buna-N	-20 to 250	-29 to 121
Viton	-20 to 400	-29 to 204
EPDM	-40 to 300	-40 to 149

**Subject to limitations of body material.

Applicable Standards
• Design ASME B16.24
• Testing API 598
• Conforms to API 594 & 6D
• MSS SP – 6
• MSS SP – 25
• MSS SP – 55

FLOW COEFFICIENTS

Size	8"	10"	12"	14"	16"	18"
C_v	1800	2600	4300	5500	7200	9400
Size	20"	24"	30"	36"	42"	48"
C_v	12600	19000	37500	60000	89000	124000

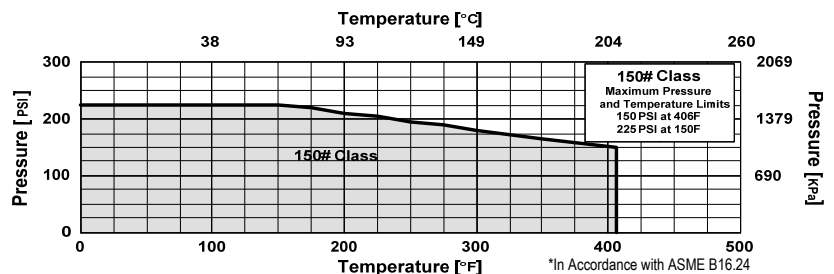

PRESSURE DROP CHART

Wafer Double Disc Check Valve (Style DD, DL, and DF)

This pressure drop chart is based on the flow of clean water through the Keckley Double Disc Check Valve. The Keckley Style DD has a cracking pressure equal to or less than 0.3 psi when mounted horizontally. Check valves should be placed at a distance equal to 5 to 10 pipe diameters from any turbulence producing device such as elbows, pumps, etc.

TO USE CHARTS:

Find your desired rate of flow (GPM) on the left hand side of the chart. Follow its corresponding horizontal line to the point where it intersects the diagonal line indicating the check valve pipe size. From this point of intersection, follow the vertical line down to the bottom of the chart to determine the approximate pressure drop.

