

Style DD

Cast Iron (ASTM A 126, Class B)
125 lb.

Carbon Steel (ASTM A 216, Grade WCB)
150 lb. Thru 1500 lb.

Stainless Steel (ASTM A 351, Grade CF8M)
150 lb. Thru 1500 lb.



Style DL



Style DF



Wafer Double Disc Check Valve

APPLICATIONS

Liquid or gas where protection from flow reversal in a pipeline is required.

CONSTRUCTION

The Keckley Wafer Double Disc Check Valves are constructed from rugged castings that are machined to exacting specifications. Reference individual technical data pages for standard disc, shaft, spring, and elastomer seat.

FEATURES

- A short face-to-face dimension.
- Lighter weight, by 80-90% than non-conventional full-body check valves.
- Spring-loaded, double disc design has a low cracking pressure.
- The tension spring performs a lifting motion on the disc to prevent excessive wear on the “heel” area of the elastomer seat.
- The independent, dual shaft design allows interchangeability of shafts. The stop shaft stabilizes the discs during high flow rates.
- Epoxy coating is standard.
- Field serviceable without the need for special tools.

INSTALLATION

The Keckley Wafer Double Disc Check Valves are used in both vertical and horizontal applications. For horizontal flow applications the shaft should be vertically oriented. Contact Keckley for downward vertical flow installations.

ORDERING

Reference page [C2](#) for Keckley Check Valve Product Numbers.

WORKING PRESSURES – NON SHOCK

NOM. RATING	BODY MATERIAL	MEDIA	2" to 12"	14" to 24"
125#	CAST IRON (ASTM A 126, CLASS B)	W.O.G.	200 PSI @ 150°F	150 PSI @ 150°F
NOM. RATING	BODY MATERIAL	MEDIA	2" to 24"	
150#	CARBON STEEL (ASTM A 216, GRADE WCB)	W.O.G.	285 PSI @ 100°F	
	STAINLESS STEEL (ASTM A 351, GRADE CF8M)	W.O.G.	275 PSI @ 100°F	
NOM. RATING	BODY MATERIAL	MEDIA	2" to 24"	
300#	CARBON STEEL (ASTM A 216, GRADE WCB)	W.O.G.	740 PSI @ 100°F	
	STAINLESS STEEL (ASTM A 351, GRADE CF8M)	W.O.G.	720 PSI @ 100°F	

Style DF

**Retainerless Wafer Double Flange Body
Double Disc Check Valve, 300 lb.
Duplex (ASTM A 351, Grade CD4MCu)**

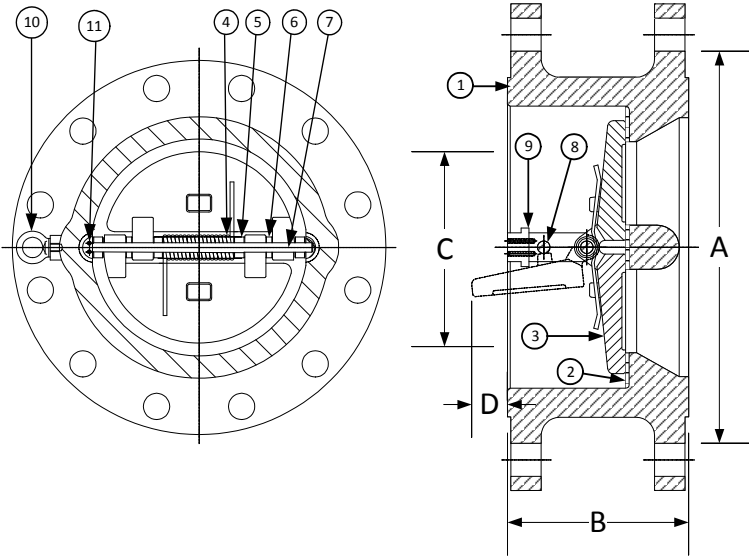

PARTS LIST		
ITEM	DESCRIPTION	MATERIAL
1	Body	Duplex (ASTM A 351, Grade CD4MCu)
2	Seat	Viton O-Ring
3	Disc	Duplex (ASTM A 351, Grade CD4MCu)
4	Spring	Inconel X-750
5	Spring Plate	Stainless Steel (ASTM A 182, Grade F-316)
6	Thrust Washer	Stainless Steel (ASTM A 182, Grade F-316)
7	Hinge Pin	Stainless Steel (ASTM A 182, Grade F-316)
8	Stop Pin	Stainless Steel (ASTM A 182, Grade F-316)
9	Locating Piece	Stainless Steel (ASTM A 182, Grade F-316)
10	Lifting Lug	Carbon Steel
11	Screw	Stainless Steel (316)

Above "Standard" Product Number – **DF4R-DP-DP4IX**
Other Options - Reference **C2** for available materials.

SIZE		DIMENSIONS						WEIGHTS	
		A		B		C*			
in	mm	in	mm	in	mm	in	mm	lbs	kgs
8	200	12-1/8	308	5	127	7-1/2	191	151	68
10	250	14-1/4	362	5-3/4	146	9-7/16	240	251	114
12	300	16-5/8	422	7-1/8	181	11-3/8	289	465	211
14	350	19-1/8	486	8-3/4	222	12-1/2	318	593	269
16	400	21-1/4	540	9-1/8	232	14-3/8	365	771	350
18	450	23-1/2	597	10-3/8	264	16-1/8	409	970	440
20	500	25-3/4	654	11-1/2	292	17-7/8	454	1078	488
24	600	30-1/2	775	12-1/2	318	22-1/8	562	1516	686
30	750	37-1/2	953	14-1/2	368	28-3/4	730	3100	1406
36	900	44	1118	19	483	35	864	4650	2109
42	1050	45-7/8	1289	22-3/8	568	41	1041	8670	3932
48	1200	52-1/8	1492	24-3/4	629	47	1193	9950	4513

*Minimum companion flange bore.

Available with thru-hole bolting or threaded bolt holes.

Sizes 30" and larger fit **Series A** flanges.

Seat Material	Operating Temperature**	
	°F	°C
Buna-N	-20 to 250	-29 to 121
Viton	-20 to 400	-29 to 204
EPDM	-40 to 300	-40 to 149

**Subject to limitations of body material.

Applicable Standards
• Design ASME B16.5
• Design ASME B16.34
• Testing API 598
• Conforms to API 594 & 6D
• MSS SP – 6
• MSS SP – 25
• MSS SP – 55

FLOW COEFFICIENTS						
Size	8"	10"	12"	14"	16"	18"
C _v	1800	2600	4300	5500	7200	9400
Size	20"	24"	30"	36"	42"	48"
C _v	12600	19000	37500	60000	89000	124000

PRESSURE DROP CHART

Wafer Double Disc Check Valve (Style DD, DL, and DF)

This pressure drop chart is based on the flow of clean water through the Keckley Double Disc Check Valve. The Keckley Style DD has a cracking pressure equal to or less than 0.3 psi when mounted horizontally. Check valves should be placed at a distance equal to 5 to 10 pipe diameters from any turbulence producing device such as elbows, pumps, etc.

TO USE CHARTS:

Find your desired rate of flow (GPM) on the left hand side of the chart. Follow its corresponding horizontal line to the point where it intersects the diagonal line indicating the check valve pipe size. From this point of intersection, follow the vertical line down to the bottom of the chart to determine the approximate pressure drop.

