

Style DD

Cast Iron (ASTM A 126, Class B)
125 lb.

Carbon Steel (ASTM A 216, Grade WCB)
150 lb. Thru 1500 lb.

Stainless Steel (ASTM A 351, Grade CF8M)
150 lb. Thru 1500 lb.



Style DL



Style DF



Wafer Double Disc Check Valve

APPLICATIONS

Liquid or gas where protection from flow reversal in a pipeline is required.

CONSTRUCTION

The Keckley Wafer Double Disc Check Valves are constructed from rugged castings that are machined to exacting specifications. Reference individual technical data pages for standard disc, shaft, spring, and elastomer seat.

FEATURES

- A short face-to-face dimension.
- Lighter weight, by 80-90% than non-conventional full-body check valves.
- Spring-loaded, double disc design has a low cracking pressure.
- The tension spring performs a lifting motion on the disc to prevent excessive wear on the “heel” area of the elastomer seat.
- The independent, dual shaft design allows interchangeability of shafts. The stop shaft stabilizes the discs during high flow rates.
- Epoxy coating is standard.
- Field serviceable without the need for special tools.

INSTALLATION

The Keckley Wafer Double Disc Check Valves are used in both vertical and horizontal applications. For horizontal flow applications the shaft should be vertically oriented. Contact Keckley for downward vertical flow installations.

ORDERING

Reference page [C2](#) for Keckley Check Valve Product Numbers.

WORKING PRESSURES – NON SHOCK

NOM. RATING	BODY MATERIAL	MEDIA	2" to 12"	14" to 24"
125#	CAST IRON (ASTM A 126, CLASS B)	W.O.G.	200 PSI @ 150°F	150 PSI @ 150°F
NOM. RATING	BODY MATERIAL	MEDIA	2" to 24"	
150#	CARBON STEEL (ASTM A 216, GRADE WCB)	W.O.G.	285 PSI @ 100°F	
	STAINLESS STEEL (ASTM A 351, GRADE CF8M)	W.O.G.	275 PSI @ 100°F	
NOM. RATING	BODY MATERIAL	MEDIA	2" to 24"	
300#	CARBON STEEL (ASTM A 216, GRADE WCB)	W.O.G.	740 PSI @ 100°F	
	STAINLESS STEEL (ASTM A 351, GRADE CF8M)	W.O.G.	720 PSI @ 100°F	

Style DF

**Retainerless Wafer Double Flange Body
 Double Disc Check Valve, 600 lb.
 Monel (ASTM A 494, Grade M35-2)**

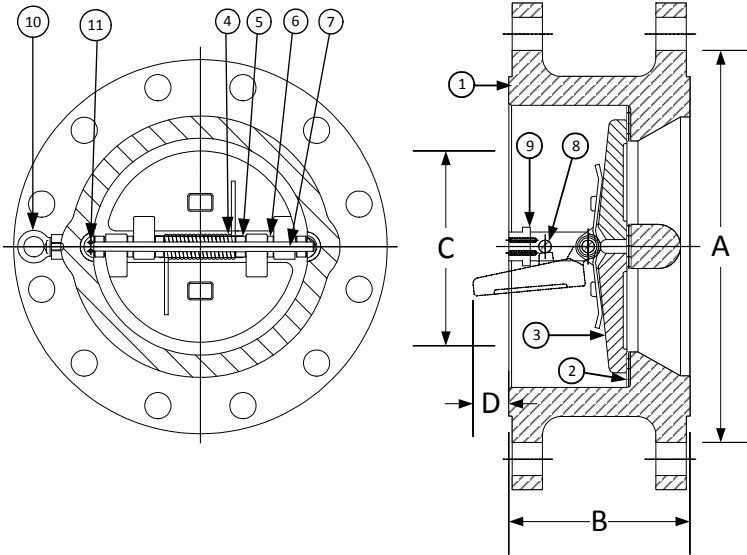
PARTS LIST

ITEM	DESCRIPTION	MATERIAL
1	Body	Monel (ASTM A 494, Grade M35-2)
2	Seat	Viton O-Ring
3	Disc	Monel (ASTM A 494, Grade M35-2)
4	Spring	Inconel X-750
5	Spring Plate	Stainless Steel (ASTM A 182, Grade F-316)
6	Thrust Washer	Stainless Steel (ASTM A 182, Grade F-316)
7	Hinge Pin	Stainless Steel (ASTM A 182, Grade F-316)
8	Stop Pin	Stainless Steel (ASTM A 182, Grade F-316)
9	Locating Piece	Stainless Steel (ASTM A 182, Grade F-316)
10	Lifting Lug	Carbon Steel
11	Screw	Stainless Steel (316)

Above "Standard" Product Number – **DF5R-ML-ML4IX**

Other Options - Reference **C2** for available materials.

SIZE		DIMENSIONS						WEIGHTS	
		A		B		C*			
in	mm	in	mm	in	mm	in	mm	lbs	kgs
12	300	18	457	9	229	11-3/8	289	612	277
14	350	19-3/8	492	10-3/4	273	12-1/2	318	826	375
16	400	22-1/4	565	12	305	14-3/8	365	951	430
18	450	24-1/8	613	14-1/4	362	16-1/8	409	1433	650
20	500	26-7/8	683	14-1/2	368	18	457	1763	800
24	600	31-1/8	791	17-1/4	438	21-9/16	548	2755	1250
30	750	38-1/4	972	19-7/8	505	28-3/4	730	5070	2300
36	900	44-1/2	1130	25	635	33-3/4	857	7605	3450
42	1050	48	1219	27-37-64	701	39-1/2	1003	9985	4529
48	1200	-	-	31	787	36	914	12600	5715

*Minimum companion flange bore.

Available with thru-hole bolting or threaded bolt holes.

Sizes 30" and larger fit **Series A** flanges.

Seat Material	Operating Temperature**	
	°F	°C
Buna-N	-20 to 250	-29 to 121
Viton	-20 to 400	-29 to 204
EPDM	-40 to 300	-40 to 149

**Subject to limitations of body material.

Applicable Standards
• Design ASME B16.5
• Design ASME B16.34
• Testing API 598
• Conforms to API 594 & 6D
• MSS SP – 6
• MSS SP – 25
• MSS SP – 55

FLOW COEFFICIENTS

Size	12"	14"	16"	18"	20"	24"
C _v	4300	5500	7200	9400	12600	19000
Size	30"	36"	42"	48"		
C _v	37500	60000	89000	12400		

PRESSURE DROP CHART

Wafer Double Disc Check Valve (Style DD, DL, and DF)

This pressure drop chart is based on the flow of clean water through the Keckley Double Disc Check Valve. The Keckley Style DD has a cracking pressure equal to or less than 0.3 psi when mounted horizontally. Check valves should be placed at a distance equal to 5 to 10 pipe diameters from any turbulence producing device such as elbows, pumps, etc.

TO USE CHARTS:

Find your desired rate of flow (GPM) on the left hand side of the chart. Follow its corresponding horizontal line to the point where it intersects the diagonal line indicating the check valve pipe size. From this point of intersection, follow the vertical line down to the bottom of the chart to determine the approximate pressure drop.

