

DRAWING NO.
AL 105040

BODY PRESSURE & TEMPERATURE RATINGS – NON SHOCK		
NOM. RATING	MEDIA	8" to 48"
150# (WAFER DOUBLE FLANGE)	W.O.G.	285 PSI @ 100°F

PARTS LIST		
ITEM	DESCRIPTION	MATERIAL
1	BODY	CARBON STEEL (ASTM A 216, GRADE WCB)
2	SEAT*	CARBON STEEL (ASTM A 216, GRADE WCB)
3	DISC	STAINLESS STEEL (ASTM A 351, GRADE CF8M)
4	SPRING	INCONEL X-750
5	SPRING PLATE	STAINLESS STEEL (ASTM A 182, GRADE F-316)
6	THRUST WASHER	STAINLESS STEEL (ASTM A 182, GRADE F-316)
7	HINGE PIN	STAINLESS STEEL (ASTM A 182, GRADE F-316)
8	STOP PIN	STAINLESS STEEL (ASTM A 182, GRADE F-316)
9	LOCATING PIECE	STAINLESS STEEL (ASTM A 182, GRADE F-316)
10	LIFTING LUG	CARBON STEEL
11	SCREW	STAINLESS STEEL (316)

*Other Seat Materials Available in Metal (Same as Disc), 316LSS Overlay, and 410SS Overlay.

PRODUCT NUMBER†	SIZE	DIMENSIONS			WEIGHT
		A	B	C*	
8DF2R-CS-362IX	8	11	5	7-5/8	93
10DF2R-CS-362IX	10	13-3/8	5-3/4	9-9/16	189
12DF2R-CS-362IX	12	16-1/8	7-1/8	11-3/8	308
14DF2R-CS-362IX	14	17-3/4	7-1/4	12-1/2	352
16DF2R-CS-362IX	16	20-1/4	7-1/2	15	496
18DF2R-CS-362IX	18	21-5/8	8	16-7/8	551
20DF2R-CS-362IX	20	23-7/8	8-5/8	18-7/8	661
24DF2R-CS-362IX	24	28-1/4	8-3/4	22-5/8	860
30DF2R-CS-362IX	30	34-3/4	12	29-1/4	1512
36DF2R-CS-362IX	36	41-1/4	14-1/2	35	2525
42DF2R-CS-362IX	42	48	17	41	4163
48DF2R-CS-362IX	48	54-1/2	20-5/8	47	5880

*Minimum companion flange bore.

Sizes 30" and larger fit **Series A** flanges.

Available with thru-hole bolting or threaded bolt holes

†See "**Style DF Product Number Configuration**" for additional options.

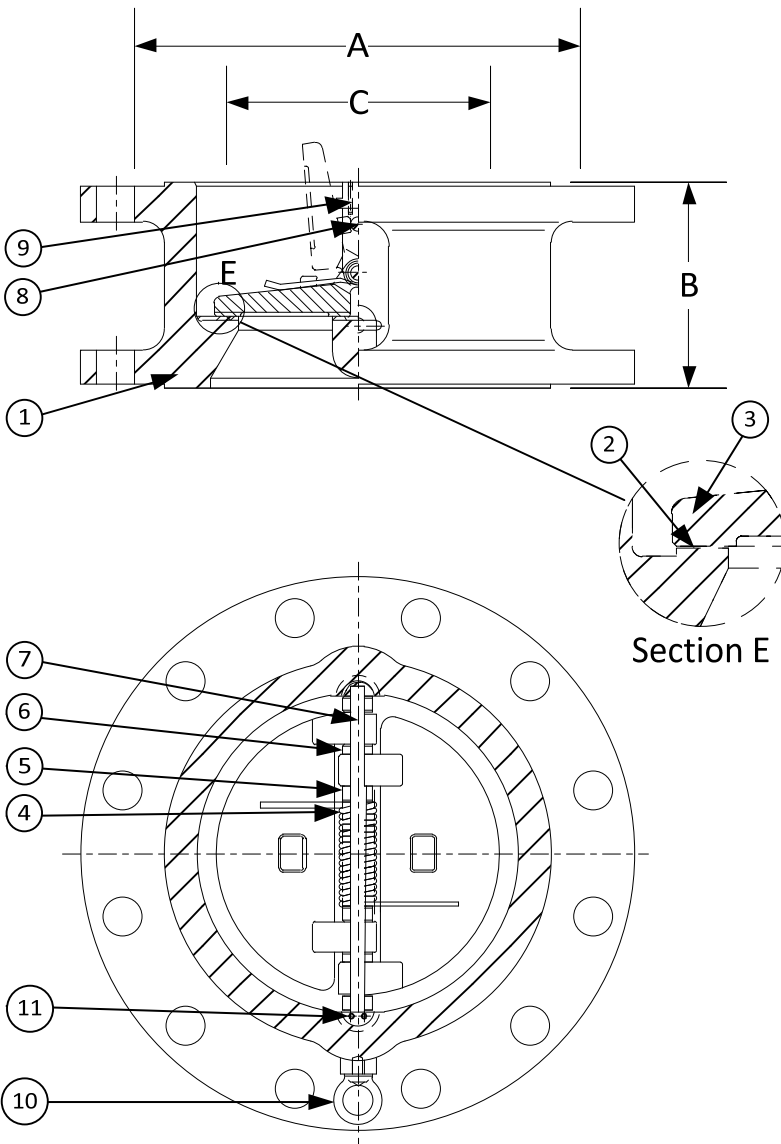

APPLICABLE STANDARDS

• Design ASME B16.5, B16.34	• MSS SP – 6
• Conform to API 594 & 6D	• MSS SP – 25
• Testing API 598	• MSS SP – 55

 3400 CLEVELAND SKOKIE ILLINOIS		DRAWING NO. AL 105040
		PART NO. DF2R-CS-362IX
DIMENSIONAL ASSEMBLY		SCALE: NTS
150# Retainerless Wafer Double Flange Body		DATE: 07/01/2011
Double Disc Check Valve		DR. BY DSF
MAT'L: Cast Carbon Steel	REQ. ---	