

DRAWING NO.  
AL 104220

BODY PRESSURE & TEMPERATURE RATINGS – NON SHOCK		
NOM. RATING	MEDIA	8" to 48"
300# (WAFFER DOUBLE FLANGE)	W.O.G.	740 PSI @ 100°F

PARTS LIST		
ITEM	DESCRIPTION	MATERIAL
1	BODY	CARBON STEEL (ASTM A 216, GRADE WCB)
2	SEAT*	VITON O-RING
3	DISC	STAINLESS STEEL (ASTM A 351, GRADE CF8M)
4	SPRING	INCONEL X-750
5	SPRING PLATE	STAINLESS STEEL (ASTM A 182, GRADE F-316)
6	THRUST WASHER	STAINLESS STEEL (ASTM A 182, GRADE F-316)
7	HINGE PIN	STAINLESS STEEL (ASTM A 182, GRADE F-316)
8	STOP PIN	STAINLESS STEEL (ASTM A 182, GRADE F-316)
9	LOCATING PIECE	STAINLESS STEEL (ASTM A 182, GRADE F-316)
10	LIFTING LUG	CARBON STEEL
11	SCREW	STAINLESS STEEL (316)

\*Other Seat Materials Available in Buna, EPDM, PTFE, and Neoprene.

PRODUCT NUMBER†	SIZE	DIMENSIONS			WEIGHT
		A	B	C*	
8DF4R-CS-364IX	8	12-1/8	5	7-1/2	151
10DF4R-CS-364IX	10	14-1/4	5-3/4	9-7/16	251
12DF4R-CS-364IX	12	20-1/2	7-1/8	11-3/8	465
14DF4R-CS-364IX	14	23	8-3/4	12-1/2	593
16DF4R-CS-364IX	16	25-1/2	9-1/8	14-3/8	771
18DF4R-CS-364IX	18	28	10-3/8	16-1/8	970
20DF4R-CS-364IX	20	30-1/2	11-1/2	17-7/8	1078
24DF4R-CS-364IX	24	36	12-1/2	22-1/8	1516
30DF4R-CS-364IX	30	43	14-1/2	28-3/4	3100
36DF4R-CS-364IX	36	50	19	35	4650
42DF4R-CS-364IX	42	50-3/4	22-3/8	41	8670
48DF4R-CS-364IX	48	57-3/4	24-3/4	47	9950

\*Minimum companion flange bore.

Sizes 30" and larger fit **Series A** flanges.

Available with thru-hole bolting or threaded bolt holes

†See "Style DF Product Number Configuration" for additional options.

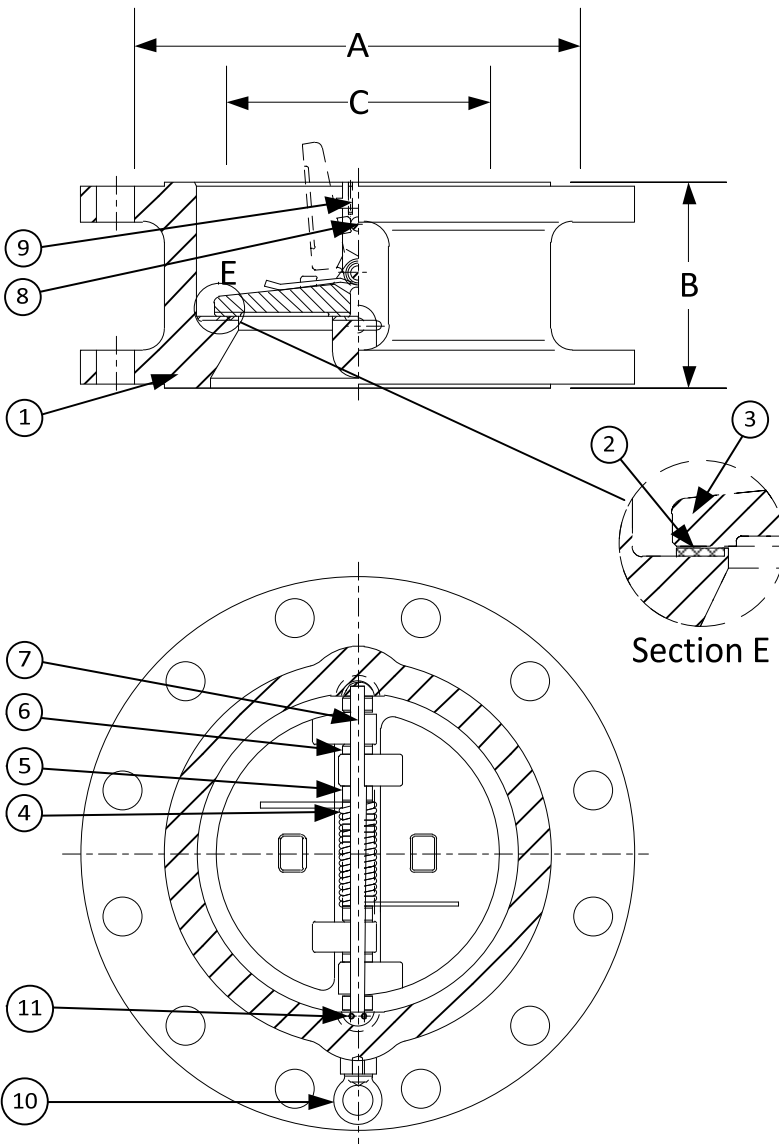

**APPLICABLE STANDARDS**

• Design ASME B16.5, B16.34	• MSS SP – 6
• Conform to API 594 & 6D	• MSS SP – 25
• Testing API 598	• MSS SP – 55

 3400 CLEVELAND SKOKIE ILLINOIS		DRAWING NO. AL 104220
		PART NO. DF4R-CS-364IX
DIMENSIONAL ASSEMBLY		SCALE: NTS
300# Retainerless Wafer Double Flange Body		DATE: 11/21/2018
Double Disc Check Valve		DR. BY DSF
MAT'L: Cast Carbon Steel	REQ. ---	