

DRAWING NO.

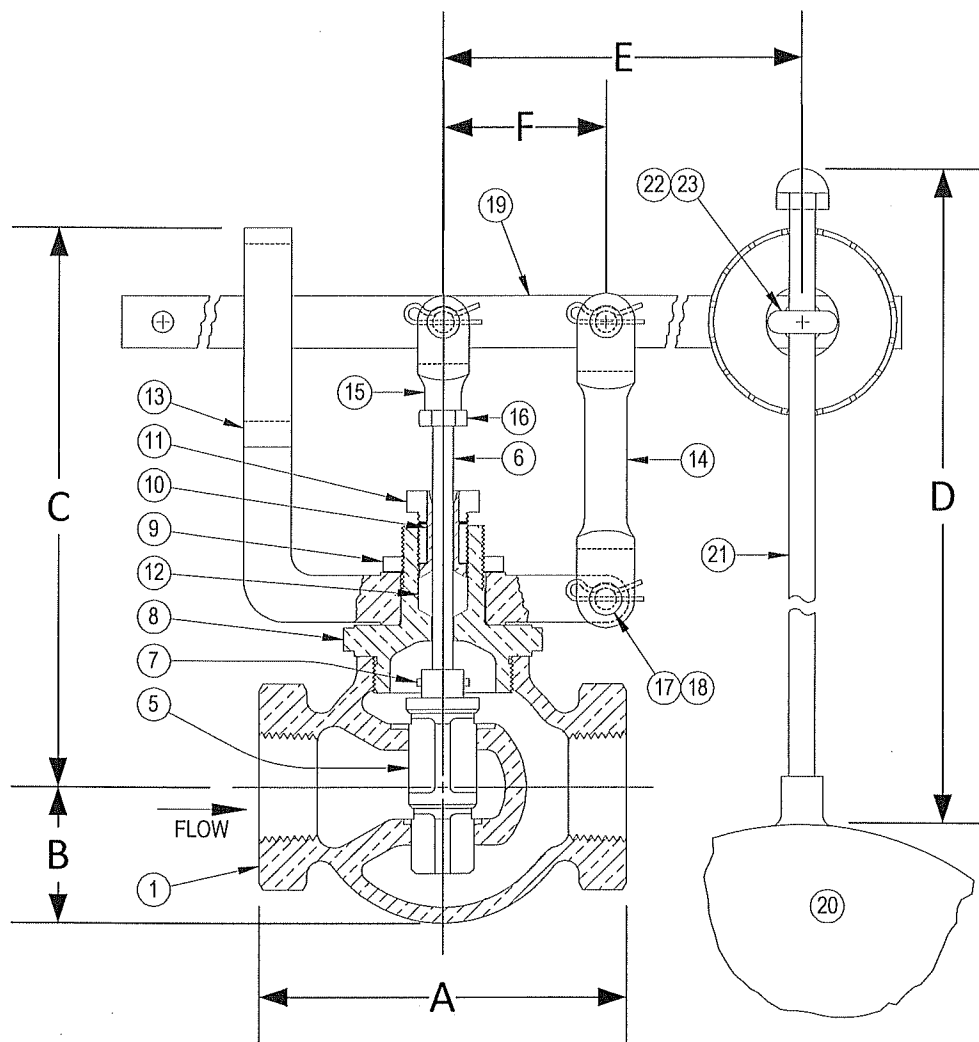

PARTS LIST

Item	Description	Material
1	BODY	STAINLESS STEEL (ASTM A 351, GRADE CF8M)
2		
3		
4		
5	INNER VALVE	STAINLESS STEEL (ASTM A 351, GRADE CF8M)
*6	VALVE STEM	STAINLESS STEEL
*7	ROLL PIN	STAINLESS STEEL
8	PACKING BOX (BONNET)	STAINLESS STEEL
9	YOKE LOCKNUT	STAINLESS STEEL
10	PACKING GLAND	STAINLESS STEEL
11	PACKING NUT	STAINLESS STEEL
*12	PACKING	TEFLON
13	GUIDE YOKE	STAINLESS STEEL (ASTM A 351, GRADE CF8M)
14	GUIDE ARM	STAINLESS STEEL (ASTM A 351, GRADE CF8M)
15	STEM CLEVIS	STAINLESS STEEL (ASTM A 351, GRADE CF8M)
16	CLEVIS LOCKNUT	STAINLESS STEEL
17	PIVOT PIN(S)	STAINLESS STEEL
18	PIVOT PIN RETAINER(S)	STAINLESS STEEL
19	LEVER ASSEMBLY	STAINLESS STEEL
20	FLOAT BALL	STAINLESS STEEL (304)
21	FLOAT ROD	STAINLESS STEEL
22	ROD RETAINER	STAINLESS STEEL
23	ROD RETAINER NUT	STAINLESS STEEL

\*Denotes parts included in the rebuild kit.

Size	DIMENSIONS							Float Dia.	Max Inlet	WEIGHT
	A	B	C	D	E	F				
(in)	(in)	(in)	(in)	(in)	(in)	(in)	(in)	(PSI)	(lbs)	
1/2	4	1-1/2	6-1/8	16	13-11/16	1-15/16	7	150	10	
3/4	4	1-1/2	6-1/8	16	13-11/16	1-15/16	7	150	10	
1	4-3/8	1-5/8	6-5/16	16	13-11/16	1-15/16	7	150	13	
1-1/4	4-1/2	1-3/4	6-3/4	16	13-11/16	1-15/16	7	120	14	
1-1/2	4-1/2	1-3/4	6-3/4	16	13-11/16	1-15/16	7	120	14	

**KECKLEY**

3400 CLEVELAND SKOKIE ILLINOIS

DRAWING NO.

DIMENSIONAL ASSEMBLY

PART NO.

250lb. Threaded Type 27 Globe

SCALE: NTS

Float Valve

DATE: 09/01/2011

MAT'L: SS Body / SS Trim

REQ. ---

DR. BY DSF

DRAWING NO.

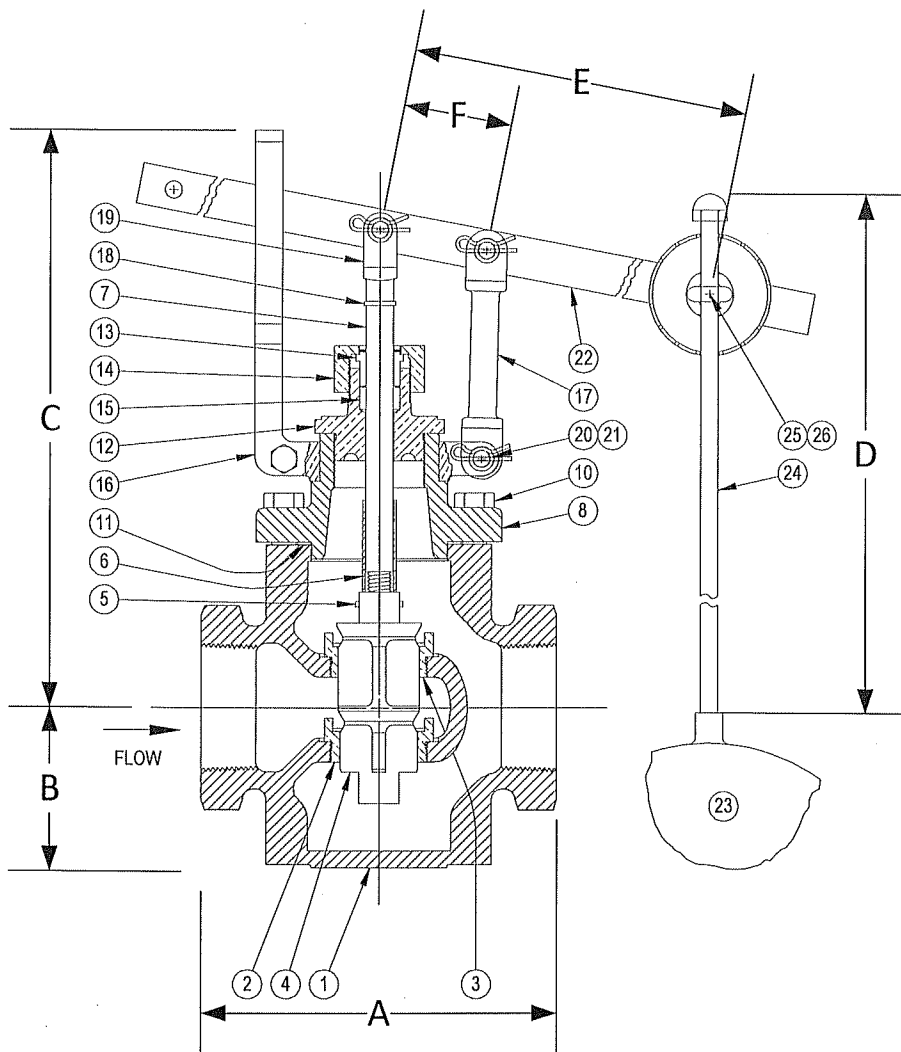

PARTS LIST

Item	Description	Material
1	BODY	STAINLESS STEEL (ASTM A 351, GRADE CF8M)
*2	SEAT BUSHING (SMALL - LOWER)	STAINLESS STEEL (ASTM A 351, GRADE CF8M)
*3	SEAT BUSHING (LARGER - UPPER)	STAINLESS STEEL (ASTM A 351, GRADE CF8M)
*4	MAIN VALVE	STAINLESS STEEL (ASTM A 351, GRADE CF8M)
*5	SPACER	STAINLESS STEEL
6	ROLL PIN	STAINLESS STEEL
*7	VALVE STEM	STAINLESS STEEL
8	TOP CAP	STAINLESS STEEL (ASTM A 351, GRADE CF8M)
9		
10	CAP SCREW(S)	STAINLESS STEEL
*11	GASKET	FIBER
12	PACKING BOX (BONNET)	STAINLESS STEEL (ASTM A 351, GRADE CF8M)
13	PACKING GLAND	STAINLESS STEEL (ASTM A 351, GRADE CF8M)
14	PACKING NUT	STAINLESS STEEL (ASTM A 351, GRADE CF8M)
*15	PACKING	TEFLON
16	GUIDE YOKE	STAINLESS STEEL (ASTM A 351, GRADE CF8M)
17	GUIDE ARM	STAINLESS STEEL (ASTM A 351, GRADE CF8M)
18	CLEVIS LOCKWASHER	STAINLESS STEEL
19	STEM CLEVIS	STAINLESS STEEL (ASTM A 351, GRADE CF8M)
20	PIVOT PIN(S)	STAINLESS STEEL
21	PIVOT PIN RETAINER(S)	STAINLESS STEEL
22	LEVER ASSEMBLY	STAINLESS STEEL
23	FLOAT BALL	STAINLESS STEEL (304)
24	FLOAT ROD	STAINLESS STEEL
25	ROD RETAINER	STAINLESS STEEL
26	ROD RETAINER NUT	STAINLESS STEEL

\*Denotes parts included in the rebuild kit.

Size	DIMENSIONS								WEIGHT (lbs)
	A	B	C	D	E	F	Float Dia.	Max Inlet	
2	6-1/2	3	10-3/4	16	17-3/8	2	7	75	29



3400 CLEVELAND SKOKIE ILLINOIS

DIMENSIONAL ASSEMBLY

250Lb. Threaded Type 27 Globe

Float Valve

MAT'L: SS Body / SS Trim

REQ. ---

DRAWING NO.

PART NO.

SCALE: NTS

DATE: 09/01/2011

DR. BY DSF