

DRAWING NO.

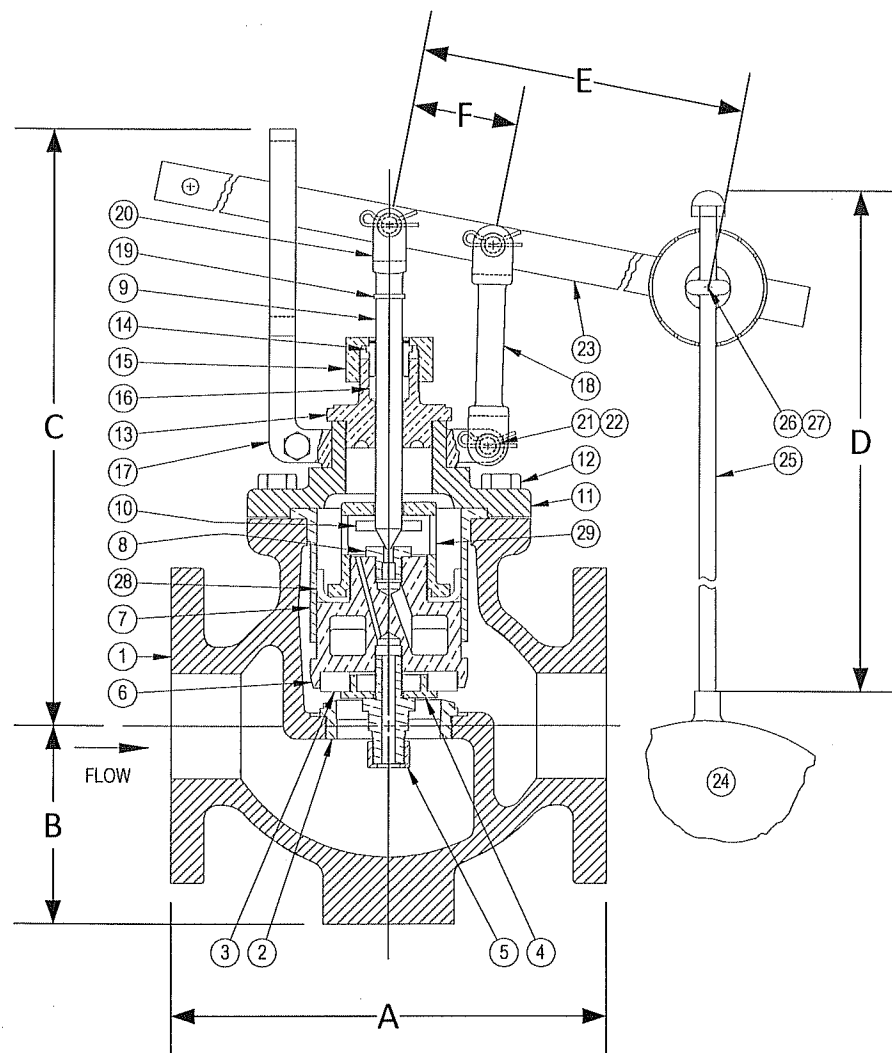

## PARTS LIST

Item	Description	Material
1	BODY	CAST IRON (ASTM A 126, CLASS B)
*2	SEAT BUSHING	BRONZE (ASTM B 62, C83600)
*13	VALVE DISC	NITRILE
4	DISC PLATE	BRONZE
5	DISC PLATE SCREW & STRAINER ASS'Y	BRASS
6	INNER VALVE	BRONZE (ASTM B 62, C83600)
7	CYLINDER	BRONZE (ASTM B 62, C83600)
*8	PORT STUD	BRONZE (ASTM B 62, C83600)
*9	VALVE STEM	STAINLESS STEEL
*10	ROLL PIN	STAINLESS STEEL
11	TOP CAP	CAST IRON (ASTM A 126, CLASS B)
12	CAP SCREW(S)	STEEL
13	PACKING BOX (BONNET)	BRONZE (ASTM B 62, C83600)
14	PACKING GLAND	BRONZE (ASTM B 62, C83600)
15	PACKING NUT	BRONZE (ASTM B 62, C83600)
*16	PACKING	TEFLON
17	GUIDE YOKE	BRONZE (ASTM B 62, C83600)
18	GUIDE ARM	BRONZE (ASTM B 62, C83600)
19	CLEVIS LOCKWASHER	STEEL
20	STEM CLEVIS	BRONZE (ASTM B 62, C83600)
21	PIVOT PIN(S)	STEEL
22	PIVOT PIN RETAINER(S)	STEEL
23	LEVER ASSEMBLY	STEEL
24	FLOAT BALL	STAINLESS STEEL (304)
25	FLOAT ROD	BRASS
26	ROD RETAINER	STEEL
27	ROD RETAINER NUT	STEEL
*28	LEATHER CUP	LEATHER
29	LEATHER CUP LOCK NUT	BRONZE

\*Denotes parts included in the rebuild kit.

†Suitable for temperatures up to 125°F. For temperature ranges above 125°F, contact Keckley.

Size	DIMENSIONS								WEIGHT (lbs)
	A	B	C	D	E	F	Float Dia.	Max Inlet (PSI)	
2	8-1/4	3	11-1/4	16	17-3/8	2	7	200	45
2-1/2	9-1/2	3-3/8	12	18	17-3/8	2	8	200	68
3	10-1/2	4	13-1/4	18	17-3/8	2	8	200	80
4	12-1/4	4-3/4	14-5/16	18	17-3/8	2	8	200	140
5	14-1/2	5-15/16	14-1/4	24	19-1/4	2-1/2	10	200	235
6	16-1/4	6-15/16	18-5/16	24	19-1/4	2-1/2	10	200	235
8	19-1/8	8-1/4	20-3/4	30	28	3	10	200	395

3400 CLEVELAND

SKOKIE ILLINOIS

DRAWING NO.

DIMENSIONAL ASSEMBLY

PART NO.

125Lb. Flange Type 77 Globe

SCALE: NTS

Float Valve

DATE: 09/01/2011

MAT'L: Iron Body / Bronze Trim

REQ. ---

DR. BY DSF