

DRAWING NO.

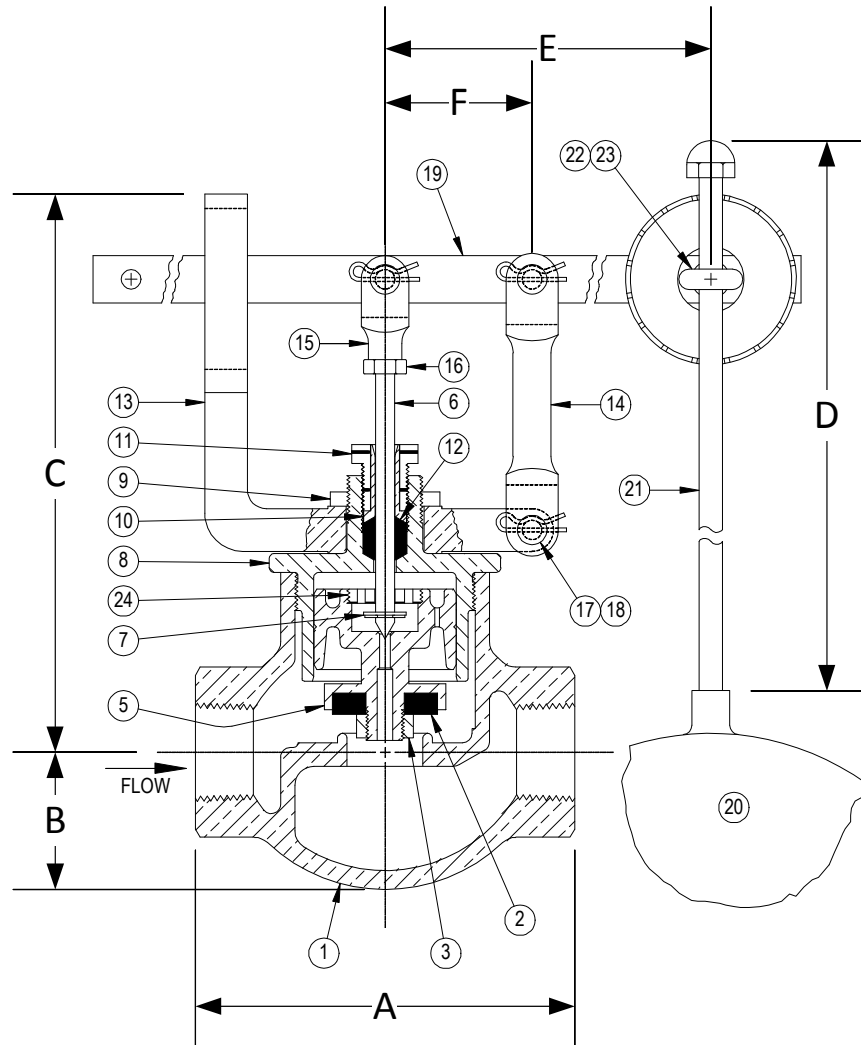

PARTS LIST

Item	Description	Material
1	BODY	STAINLESS STEEL (ASTM A 351, GRADE CF8M)
*†2	VALVE DISC	NITRILE
3	DISC NUT	STAINLESS STEEL
4		
5	INNER VALVE	STAINLESS STEEL (ASTM A 351, GRADE CF8M)
*6	VALVE STEM	STAINLESS STEEL
*7	STEM SNAP RING	STAINLESS STEEL
8	BONNET (PACKING BOX)	STAINLESS STEEL (ASTM A 351, GRADE CF8M)
9	YOKE LOCKNUT	STAINLESS STEEL (ASTM A 351, GRADE CF8M)
10	PACKING GLAND	STAINLESS STEEL
11	PACKING NUT	STAINLESS STEEL
*12	PACKING	TEFLON
13	GUIDE YOKE	STAINLESS STEEL (ASTM A 351, GRADE CF8M)
14	GUIDE ARM	STAINLESS STEEL (ASTM A 351, GRADE CF8M)
15	STEM CLEVIS	STAINLESS STEEL (ASTM A 351, GRADE CF8M)
16	CLEVIS LOCKNUT	STAINLESS STEEL (ASTM A 351, GRADE CF8M)
17	PIVOT PINS	STAINLESS STEEL
18	PIVOT PIN RETAINERS	STAINLESS STEEL
19	LEVER ASSEMBLY	STAINLESS STEEL
20	FLOAT BALL	STAINLESS STEEL
21	FLOAT ROD	STAINLESS STEEL
22	ROD RETAINER	STAINLESS STEEL
23	ROD RETAINER NUT	STAINLESS STEEL
24	LIFT NUT	STAINLESS STEEL

*Denotes parts included in the rebuild kit.

†Suitable for temperatures up to 125°F.

Size	DIMENSIONS								WEIGHT (lbs)
	A	B	C	D	E	F	Float Dia.	Max Inlet	
1/2	4-1/4	1-1/2	7	16	13-11/16	1-15/16	7	130	11
3/4	4-1/4	1-1/2	7	16	13-11/16	1-15/16	7	130	11
1	5	1-13/16	7-3/8	16	13-11/16	1-15/16	7	100	13
1-1/4	5-1/8	1-7/8	7-5/8	16	13-11/16	1-15/16	7	80	14
1-1/2	5-1/4	2-1/16	7-13/16	16	13-11/16	1-15/16	7	65	14

3400 CLEVELAND

SKOKIE ILLINOIS

DRAWING NO.

DIMENSIONAL ASSEMBLY

PART NO.

250Lb. Threaded Type 7 Globe

SCALE: NTS

Float Valve

DATE: 09/01/2011

MAT'L: SS Body / SS Trim

REQ. ---

DR. BY DSF

DRAWING NO.

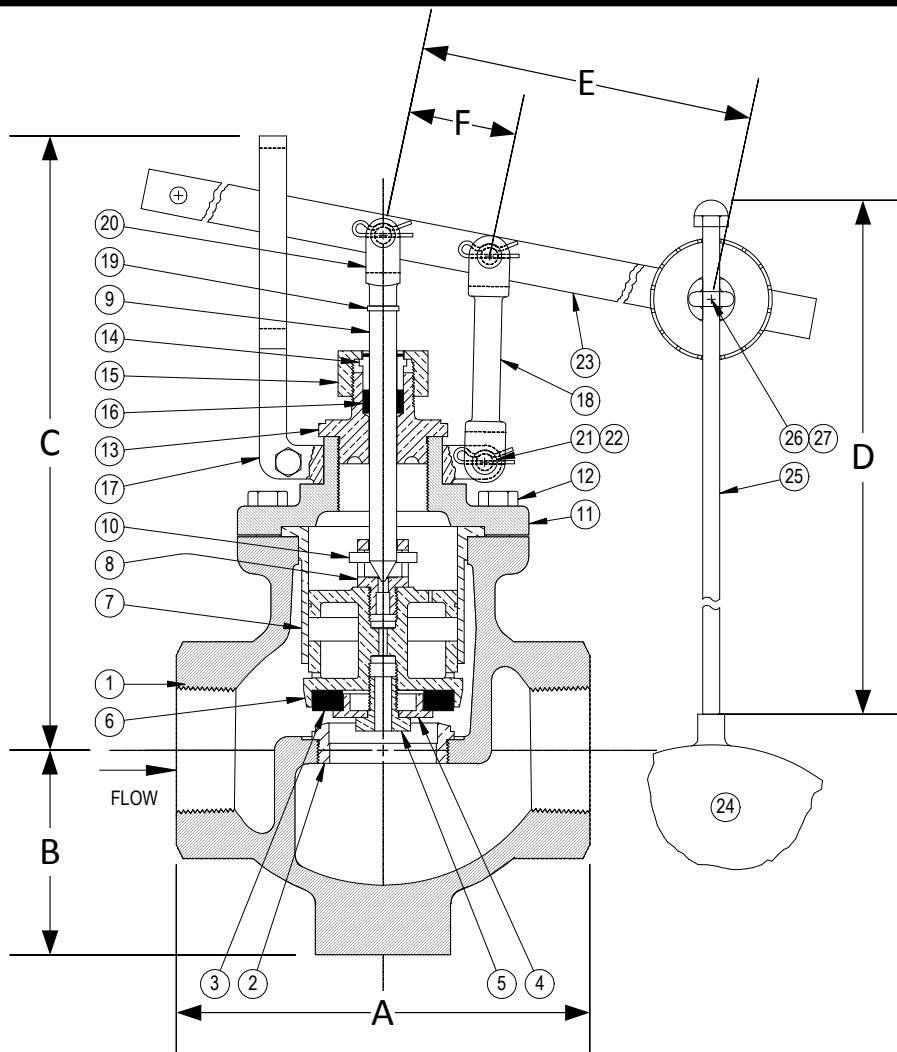

PARTS LIST

Item	Description	Material
1	BODY	STAINLESS STEEL (ASTM A 351, GRADE CF8M)
*2	SEAT BUSHING	STAINLESS STEEL (ASTM A 351, GRADE CF8M)
*†3	VALVE DISC	NITRILE
4	DISC PLATE	STAINLESS STEEL (ASTM A 351, GRADE CF8M)
5	DISC PLATE SCREW	STAINLESS STEEL
6	INNER VALVE	STAINLESS STEEL (ASTM A 351, GRADE CF8M)
7	CYLINDER	STAINLESS STEEL (ASTM A 351, GRADE CF8M)
*8	PORT STUD	STAINLESS STEEL (ASTM A 351, GRADE CF8M)
*9	VALVE STEM	STAINLESS STEEL
*10	ROLL PIN	STAINLESS STEEL
11	TOP CAP	STAINLESS STEEL (ASTM A 351, GRADE CF8M)
12	CAP SCREW(S)	STAINLESS STEEL
13	PACKING BOX (BONNET)	STAINLESS STEEL (ASTM A 351, GRADE CF8M)
14	PACKING GLAND	STAINLESS STEEL (ASTM A 351, GRADE CF8M)
15	PACKING NUT	STAINLESS STEEL (ASTM A 351, GRADE CF8M)
*16	PACKING	TEFLON
17	GUIDE YOKE	STAINLESS STEEL (ASTM A 351, GRADE CF8M)
18	GUIDE ARM	STAINLESS STEEL (ASTM A 351, GRADE CF8M)
19	CLEVIS LOCKWASHER	STAINLESS STEEL
20	STEM CLEVIS	STAINLESS STEEL (ASTM A 351, GRADE CF8M)
21	PIVOT PIN(S)	STAINLESS STEEL
22	PIVOT PIN RETAINER(S)	STAINLESS STEEL
23	LEVER ASSEMBLY	STAINLESS STEEL
24	FLOAT BALL	STAINLESS STEEL (304)
25	FLOAT ROD	STAINLESS STEEL
26	ROD RETAINER	STAINLESS STEEL
27	ROD RETAINER NUT	STAINLESS STEEL

*Denotes parts included in the rebuild kit.

†Suitable for temperatures up to 125°F.

Size	DIMENSIONS								WEIGHT (lbs)
	A	B	C	D	E	F	Float Dia.	Max Inlet (PSI)	
(in)	(in)	(in)	(in)	(in)	(in)	(in)	(in)		
2	7-5/8	3-5/8	7-3/8	16	17-3/8	2	7	50	35

DRAWING NO.

3400 CLEVELAND

SKOKIE ILLINOIS

DIMENSIONAL ASSEMBLY

PART NO.

250Lb. Threaded Type 7 Globe

SCALE: NTS

Float Valve

DATE: 11/01/2018

MAT'L: SS Body / SS Trim

REQ. ---

DR. BY DSF