

DESIGN	2" to 24"
	150 PSI COLD WORKING PRESSURE

DRAWING NO.
AL 110760

PARTS LIST

ITEM	DESCRIPTION	MATERIAL
1	Body	Stainless Steel (ASTM A 351, Grade CF8)
2	Inner Hex Head Screws (4)	Stainless Steel (ASTM A 193, Grade B8)
3	Gate	Stainless Steel (ASTM A 276, Grade F-304)
4	Valve Seats (2)	Stainless Steel (ASTM A 351, Grade CF8)
4a	Valve Seat Surface* (2)	(See Below)
5	Packing	PTFE
6,13,16	Nut	Stainless Steel (ASTM A 194, Grade 8)
7	Stud	Stainless Steel (ASTM A 193, Grade B8)
8	Clamp Plate	Stainless Steel (ASTM A 351, Grade CF8)
9	Stem	Stainless Steel (ASTM A 276, Grade F-304)
10	Mounting Bracket	
11	Air Cylinder	
12	Spring Washer	Stainless Steel (ASTM A 276, Grade F-304)
14	Post (Chrome Plated)	Carbon Steel (AISI 1035)
15	Bolt	Stainless Steel (ASTM A 193, Grade B8)
17	Straight Pin	Stainless Steel (ASTM A 276, Grade F-304)
18	Cotter Pin	Stainless Steel (ASTM A 276, Grade F-304)
19	Packing Gland	Stainless Steel (ASTM A 351, Grade CF8)
20	O-Rings (2)	(Same as 4a)

*Valve Seat Surface Options: Buna-N, Viton, EPDM, and PTFE.

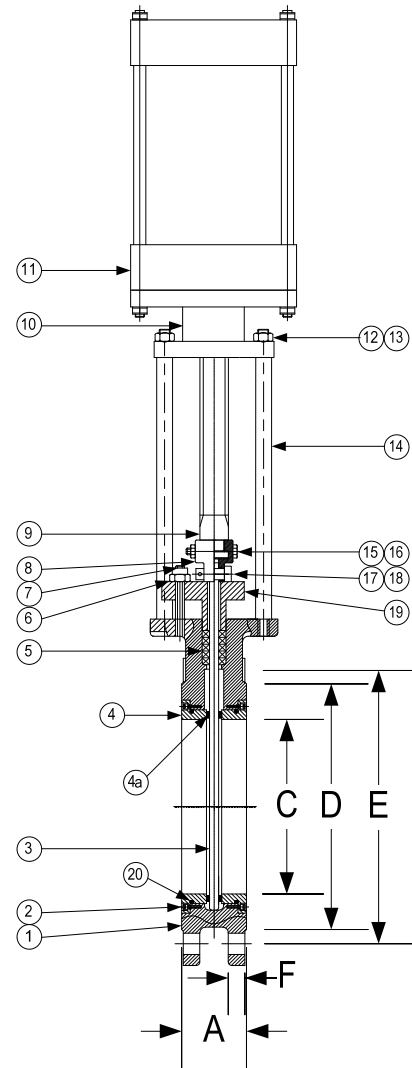

PRODUCT NUMBER	SIZE	DIMENSIONS (in)					WEIGHT (lbs)
		A	C	D	E	F	
22KGV-34-BA	2	1.88	1.81	3.62	4.75	0.50	20
21/22KGV-34-BA	2-1/2	2.00	2.36	4.13	5.50	0.50	23
32KGV-34-BA	3	2.00	2.76	5.00	6.00	0.50	27
42KGV-34-BA	4	2.00	3.78	6.20	7.50	0.50	35
52KGV-34-BA	5	2.25	4.72	7.28	8.50	0.63	47
62KGV-34-BA	6	2.25	5.71	8.50	9.50	0.63	57
82KGV-34-BA	8	2.75	7.64	10.63	11.75	0.63	86
102KGV-34-BA	10	2.75	9.65	12.76	14.25	0.75	141
122KGV-34-BA	12	3.00	11.81	15.00	17.00	0.75	187
142KGV-34-BA	14	3.00	12.99	16.26	18.75	0.81	265
162KGV-34-BA	16	3.50	14.96	18.50	21.25	0.88	381
182KGV-34-BA	18	3.50	16.54	21.00	22.75	0.94	474
202KGV-34-BA	20	4.50	18.50	23.00	25.00	1.00	637
242KGV-34-BA	24	4.50	22.44	27.26	29.50	1.00	884

B	Buna-N
V	Viton
E	EPDM
P	PTFE

 3400 CLEVELAND SKOKIE ILLINOIS	DRAWING NO. AL 110760
	PART NO. 2KGV-34-BA
DIMENSIONAL ASSEMBLY	SCALE: NTS
150# Flg. Style KGV Air Cylinder Operated	DATE: 05/13/2013
Bi-Directional Knife Gate Valve	DR. BY DSF
MAT'L: Cast Stainless Steel (304)	REQ. ---